

Front panel controller/driver with standby power management and real-time clock

Features

- IC front panel VFD controller driver
- Standby power management to the host
- 3.3 V (V_{DD}) and down to -30 V (V_{SS}) supply for the IC
- IR remote control decoder (Philips, NEC, Thomson, Sony, Matsushita)
- Multiple display modes (12 seg. and 16 digits to 20 seg and 8 digits)
- High voltage outputs ($V_{DD} - 33.3$ V max)
- No additional external resistors required for driver outputs (P-CH. open drain + pull-down resistor outputs)
- Key scanning (up to 12 x 2 matrix = 24 keys)
- LED ports (4 channels 20 mA max each)
- Serial I²C interface (SCL, SDA) communication protocol
- Operating speed: up to 400 kHz for I²C
- Programmable hotkeys for IR remote control command and KEYSCAN command
- Low power consumption in standby mode
- Dimming circuit (8 steps)
- Real-time clock (accuracy \pm 25 secs/month)
- Wake-up alarm
- Internal oscillator with external crystal for RTC
- Available in PQFP-52 package (0.65 mm pitch)

Applications

- VCR, DVD and personal video recorders
- Home theatre with clock feature, STB and HTiB (home theater in a box)

Table 1. Device summary

| Order code | Operating temperature | Package | Packaging |
|------------|-----------------------|---------|---------------|
| STFPC320 | -40°C to 85°C | PQFP-52 | Tape and reel |

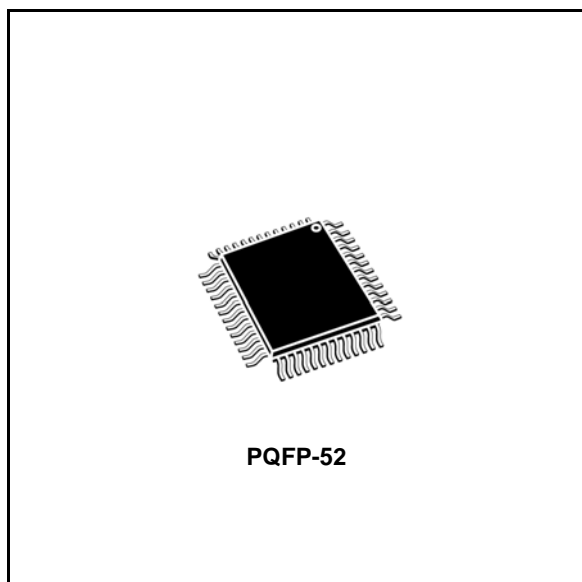

Description

The STFPC320 is designed to integrate the VFD driving, key-scan matrix, LED driving, infrared (IR) remote control decoding and real-time clock (RTC) into one integrated solution. All the functions are programmable using the I²C bus.

Low power consumption is achieved during standby operation. The STFPC320 provides the standby power management to the main chipset.

The STFPC320 is housed in a 52-pin PQFP package. The pin assignments and application circuit are optimized for an easy PCB layout and cost saving advantages.

Contents

- 1 Device block diagram 9**
- 2 Functional diagram 10**
- 3 Pin settings 11**
 - 3.1 Pin connection 11
 - 3.2 Pin description 12
- 4 Functional description 13**
 - 4.1 Reset 13
 - 4.2 Cold boot up 14
 - 4.3 Entering standby mode 15
 - 4.4 Wake-up 16
 - 4.5 Interrupts/events handling by STFPC320 17
 - 4.6 Ready pin 17
 - 4.7 Mute pin 18
 - 4.8 Keyscan matrix/front panel keys 18
 - 4.9 LED ports 18
 - 4.10 Display 18
 - 4.10.1 Normal display 18
 - 4.10.2 RTC display 18
 - 4.11 Remote control decoder 19
 - 4.12 PIN_AV8 19
 - 4.13 Default state upon power-up 19
 - 4.14 Initial state 20
- 5 Operating state diagram 21**
- 6 Real-time clock (RTC) operation 22**
 - 6.1 Real-time clock 22
 - 6.2 2-wire bus characteristics 22
 - 6.3 Watchdog timer 24

| | | |
|-----------|--|-----------|
| 6.4 | Real-time clock (RTC) | 24 |
| 6.4.1 | Reading the real-time clock | 25 |
| 6.4.2 | Writing to the real-time clock | 25 |
| 6.5 | Register table for RTC | 26 |
| 6.6 | Setting alarm clock registers | 27 |
| 6.7 | Calibrating the clock | 28 |
| 6.8 | Square wave output | 30 |
| 6.9 | Century bits | 31 |
| 6.10 | Oscillator stop detection | 31 |
| 6.11 | Initial power-on defaults | 32 |
| 7 | Commands | 33 |
| 7.1 | Configuration mode setting command | 33 |
| 7.2 | Data setting command | 36 |
| 7.3 | Display control and hotkey setting command | 38 |
| 7.4 | Example for device configuration | 41 |
| 8 | Key matrix | 42 |
| 8.1 | Key read sequence | 43 |
| 9 | LED port | 44 |
| 9.1 | Writing to LED sequence | 44 |
| 10 | SW data | 45 |
| 10.1 | Reading switch sequence | 45 |
| 11 | Address setting command | 46 |
| 11.1 | RTC display data read | 46 |
| 11.2 | Display (normal & RTC) data write | 46 |
| 12 | Normal display memory locations | 47 |
| 13 | Configuration data | 48 |
| 14 | Interrupt flags | 50 |

| | | |
|-----------|---|-----------|
| 15 | Remote control protocols | 51 |
| 15.1 | Decoded and RAW formats | 51 |
| 15.2 | Sending IR data on I ² C interface | 51 |
| 15.3 | Philips RC-5 remote control protocol | 52 |
| 15.3.1 | RC-5 data in decoded format | 53 |
| 15.3.2 | RC-5 data in RAW format | 53 |
| 15.4 | NEC remote control protocol | 54 |
| 15.4.1 | NEC in decoded format | 55 |
| 15.4.2 | NEC in RAW format | 55 |
| 15.5 | Sony remote control format | 56 |
| 15.5.1 | Sony in decoded format | 57 |
| 15.5.2 | Sony in RAW format | 57 |
| 15.6 | Matsushita remote control format | 58 |
| 15.6.1 | Matsushita in decoded format | 59 |
| 15.6.2 | Matsushita in RAW format | 60 |
| 15.7 | R2000 remote control format | 61 |
| 15.7.1 | R2000 in decoded format | 62 |
| 15.7.2 | R2000 in RAW format | 62 |
| 15.8 | RCA remote control format | 63 |
| 15.8.1 | RCA in decoded format | 64 |
| 15.8.2 | RCA in RAW format | 64 |
| 16 | Serial communication format | 65 |
| 17 | Electrical characteristics | 68 |
| 17.1 | Absolute maximum ratings | 68 |
| 17.2 | Recommended operating conditions | 68 |
| 17.3 | Power consumption estimation | 69 |
| 17.4 | Electrical specifications | 70 |
| 17.5 | Crystal electrical characteristics | 71 |
| 17.6 | Oscillator characteristics | 71 |
| 17.7 | Timing characteristics | 72 |
| 17.8 | Switching characteristics | 73 |
| 18 | STFPC320 typical application circuit | 74 |

| | | |
|----|-------------------------------|----|
| 19 | Package mechanical data | 75 |
| 20 | Revision history | 77 |

List of tables

| | | |
|-----------|---|----|
| Table 1. | Device summary | 1 |
| Table 2. | Pin description | 12 |
| Table 3. | Default state | 19 |
| Table 4. | Register table for RTC | 26 |
| Table 5. | Alarm repeat modes | 27 |
| Table 6. | Square wave output frequency | 30 |
| Table 7. | Century bits. | 31 |
| Table 8. | Initial power-on default values of the registers | 32 |
| Table 9. | Data write command. b5 b4: 00 | 36 |
| Table 10. | Data read 1 command. b5 b4: 10 | 36 |
| Table 11. | Data read 2 command. b5 b4: 11 | 36 |
| Table 12. | Display RAM address and display mode | 47 |
| Table 13. | Sony remote control format | 56 |
| Table 14. | Matsushita remote control format | 59 |
| Table 15. | Absolute maximum ratings (TA = 25°C, GND = 0 V) | 68 |
| Table 16. | Recommended operating conditions (TA = -20 to +70°C, GND = 0V) | 68 |
| Table 17. | Electrical specifications (TA = -20 to +70 °C, VDD = 3.3 V, GND = 0 V, VSS = VDD – 33.3 V)70 | |
| Table 18. | Crystal electrical characteristics | 71 |
| Table 19. | Oscillator characteristics. | 71 |
| Table 20. | Switching characteristics (TA = -20 to +70 °C, VDD = 3.3V, VSS = -30V)73 | |
| Table 21. | Switching characteristics (TA = -20 to +70 °C, VDD = 3.3V, VSS = -30V) | 73 |
| Table 22. | PQFP52 (10 x 10 x 2 mm) mechanical data. | 76 |
| Table 23. | Document revision history | 77 |

List of figures

| | | |
|------------|---|----|
| Figure 1. | STFPC320 block diagram. | 8 |
| Figure 2. | Functional diagram | 9 |
| Figure 3. | Pin connection (top view) | 10 |
| Figure 4. | Power-up behaviour | 13 |
| Figure 5. | Standby mode behaviour | 14 |
| Figure 6. | Wake-up | 15 |
| Figure 7. | Interrupts/events handling | 16 |
| Figure 8. | Operating state diagram | 20 |
| Figure 9. | Serial bus data transfer sequence | 22 |
| Figure 10. | Acknowledgement sequence | 22 |
| Figure 11. | Alarm interrupt reset waveform. | 26 |
| Figure 12. | Crystal accuracy across temperature | 28 |
| Figure 13. | Calibrating waveform | 28 |
| Figure 14. | First byte format after configuration byte | 33 |
| Figure 15. | Second byte format after configuration byte | 34 |
| Figure 16. | 14-segment + dotpoint display | 38 |
| Figure 17. | Front panel hotkeys configuration. | 39 |
| Figure 18. | Key matrix and key-input data storage RAM | 41 |
| Figure 19. | LED byte format | 43 |
| Figure 20. | LED byte format | 44 |
| Figure 21. | Configuration data bytes. | 47 |
| Figure 22. | Configuration data bytes (continued) | 48 |
| Figure 23. | Interrupt byte format | 49 |
| Figure 24. | IR data format | 50 |
| Figure 25. | Bi-phase coding | 51 |
| Figure 26. | RC-5 protocol frame | 51 |
| Figure 27. | Example of RC-5 transmission | 51 |
| Figure 28. | RC-5 data structure in decoded format. | 52 |
| Figure 29. | RC-5 data structure in raw format. | 52 |
| Figure 30. | Pulse distance modulation | 53 |
| Figure 31. | The transmitted waveform for NEC protocol. | 53 |
| Figure 32. | NEC data structure in decoded format | 54 |
| Figure 33. | NEC data structure in raw format | 54 |
| Figure 34. | Output code waveform timing definitions | 55 |
| Figure 35. | Sony data structure in decoded format. | 56 |
| Figure 36. | Sony data structure in raw format. | 56 |
| Figure 37. | Matsushita remote control protocol. | 57 |
| Figure 38. | Matsushita data structure in decoded format | 58 |
| Figure 39. | Matsushita data structure in raw format | 59 |
| Figure 40. | Thomson R2000 remote control protocol | 60 |
| Figure 41. | R2000 data structure in decoded format | 61 |
| Figure 42. | R2000 data structure in raw format | 61 |
| Figure 43. | Thomson RCA remote control protocol | 62 |
| Figure 44. | RCA data structure in decoded format | 63 |
| Figure 45. | RCA data structure in raw format | 63 |
| Figure 46. | Complete data transfer | 64 |
| Figure 47. | Valid data changes on the SDA bus | 64 |
| Figure 48. | Valid start and stop conditions | 64 |

| | | |
|------------|--|----|
| Figure 49. | Acknowledge response from receiver | 64 |
| Figure 50. | Bus timing requirements sequence | 65 |
| Figure 51. | Slave address location | 65 |
| Figure 52. | Read mode sequence | 65 |
| Figure 53. | Alternative READ mode sequence | 66 |
| Figure 54. | WRITE mode sequence | 66 |
| Figure 55. | Key scanning and display timing | 71 |
| Figure 56. | Typical application circuit | 73 |
| Figure 57. | PQFP52L package outline | 74 |

1 Device block diagram

Figure 1. STFPC320 block diagram

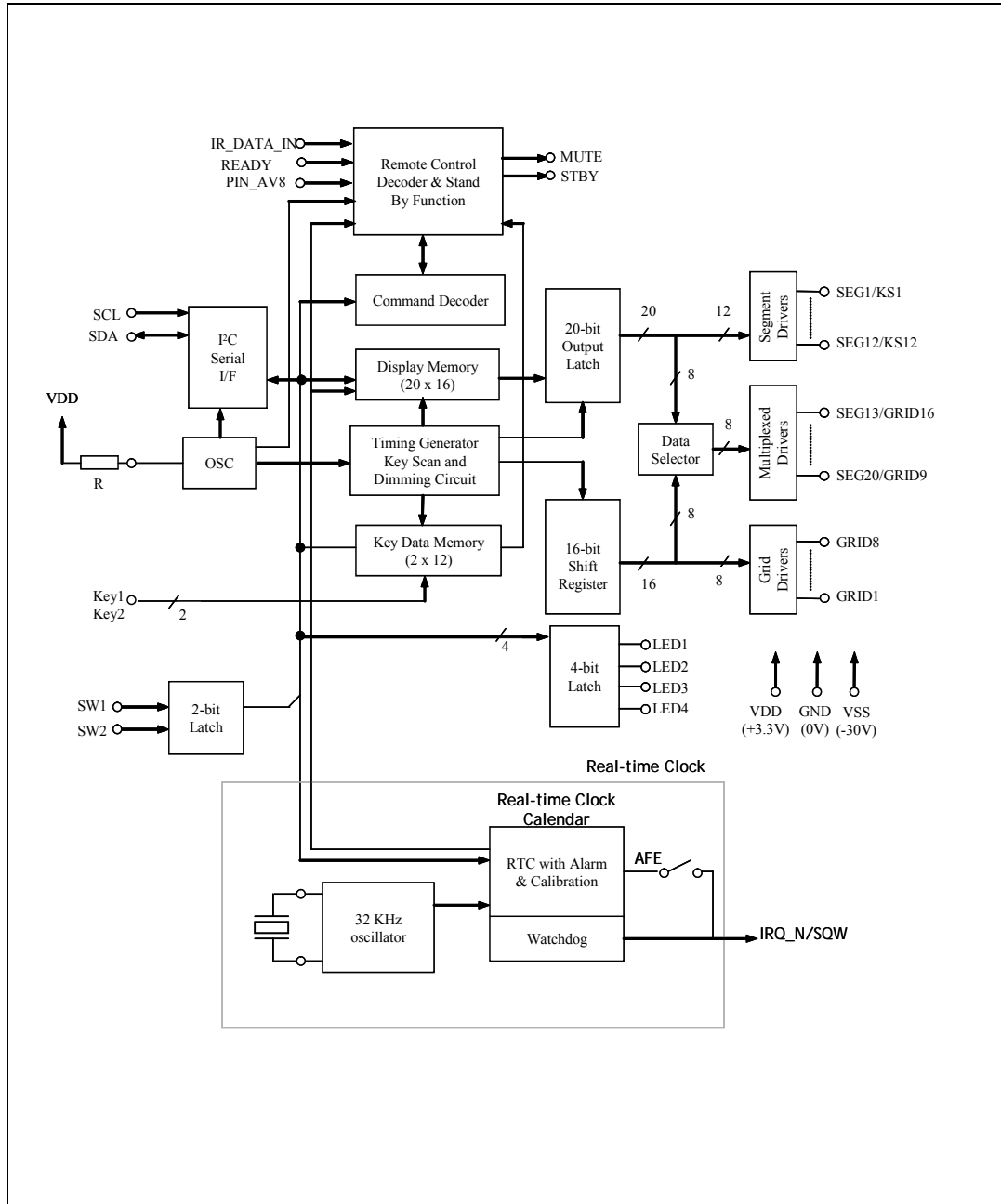

2 Functional diagram

Figure 2. Functional diagram

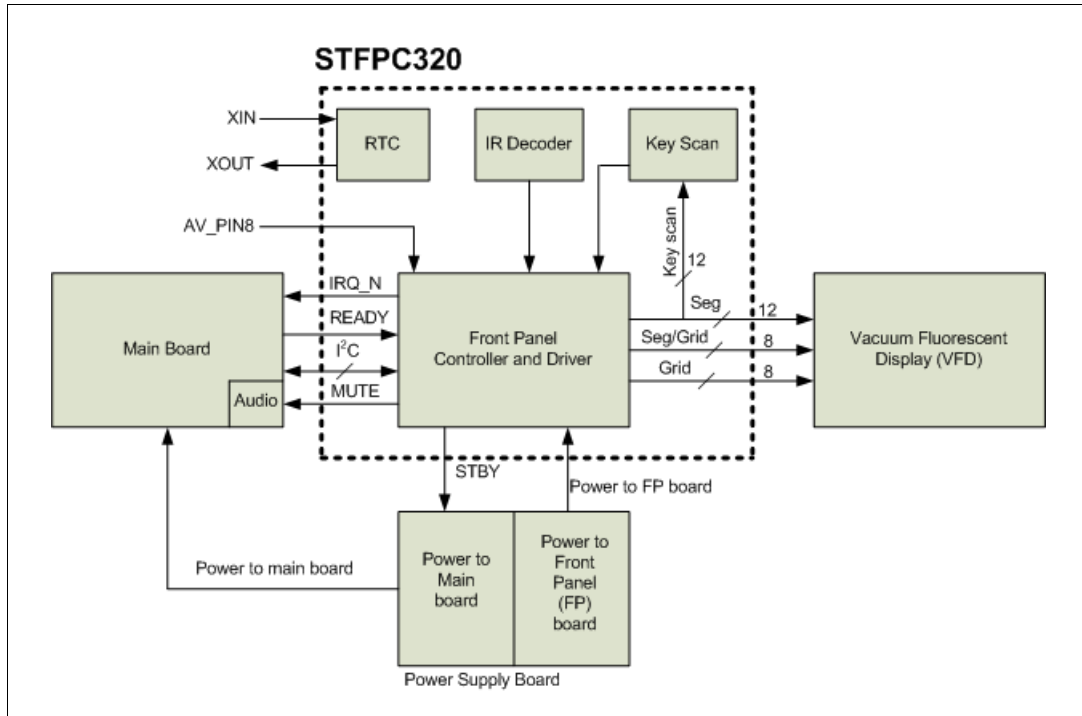

3 Pin settings

3.1 Pin connection

Figure 3. Pin connection (top view)

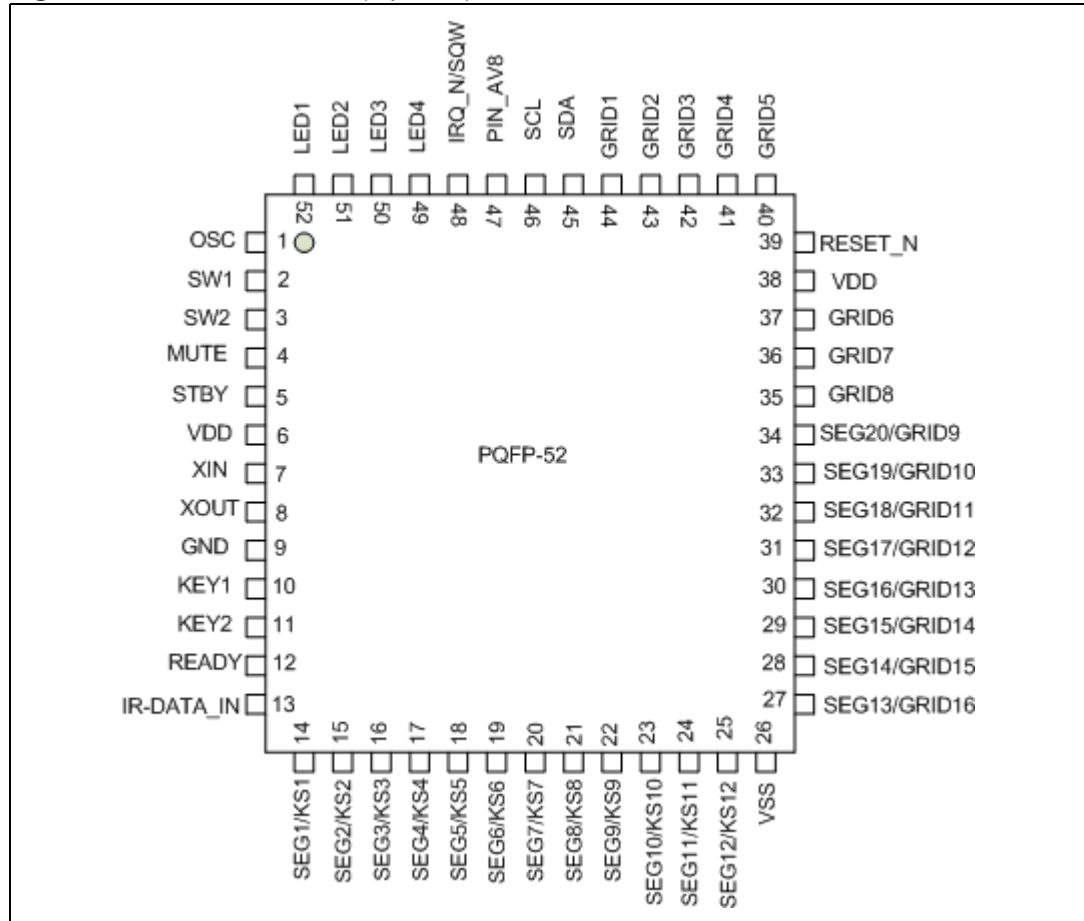

Note: For a description of each pin behaviour, please refer to the STFPC320 [Table 2: Pin description on page 12](#)

3.2 Pin description

Table 2. Pin description

| Pin N° | Name | Type | Description |
|-------------------|--------------------------------|--------|---|
| 1 | OSC | IN | Connect to an external resistor of value $33\text{ k}\Omega \pm 1\%$ |
| 2 | SW1 | IN | General purpose switch input port. |
| 3 | SW2 | IN | General purpose switch input port. |
| 4 | MUTE | OUT | High level means mute status for audio. Low level stands for normal working. |
| 5 | STBY | OUT | Pin to control power to the main board. High level means standby status. Low level stands for normal working. Active high. |
| 6, 38 | VDD | SUPPLY | $3.3\text{ V} \pm 10\%$. Core main supply voltage. |
| 7 | XIN | IN | Oscillator input pin. 32.768 KHz crystal. |
| 8 | XOUT | OUT | Oscillator output pin. 32.768 KHz crystal. |
| 9 | GND | SUPPLY | Connect this pin to system GND. |
| 10,11 | KEY1, KEY2 | IN | Input data to these pins from external keyboard are latched at end of the display cycle (maximum keyboard size is 12×2). |
| 12 | READY | IN | High level on this pin means that main board chip has been working normally. Connect an external pull down resistor of $10\text{k}\Omega$ on this pin. |
| 13 | IR_DATA_IN | IN | Remote control input. Connect to IR photodiode. |
| 14 to 25 | SEG1/KS1 to SEG12/KS12 | OUT | Segment output pins (dual function as key source). |
| 26 | VSS | SUPPLY | VFD outputs high voltage pull-down level. $VDD - 33.3\text{ V max.}$ |
| 27 to 34 | SEG13/GRID16 to SEG20/GRID9 | OUT | These pins are selectable for segment or grid driving. |
| 35-37 | GRID8 to GRID6 | OUT | Grid output pins. |
| 39 | RESET_N | IN | Active low reset input. |
| 40-44 | GRID5 to GRID1 | OUT | Grid output pins. |
| 45 | SDA | IN/OUT | Serial data in/out. Connect to 3.3 V through an external pull-up resistor. |
| 46 | SCL | IN | Serial clock input. Connect to 3.3 V through an external pull-up resistor. |
| 47 | PIN_AV8 | IN | A rising edge transition on this input will signal wake-up operation. This signal comes from the SCART interface. The micro processor can use this signal to start the recording or take other actions. |
| 48 | IRQ_N/SQW | OUT | Interrupt/square wave output (open drain). A pull up resistor of $10\text{ k}\Omega$ must be connected on this pin. |
| 49, 50, 51, 52 | LED4, LED3, LED2, LED1 | OUT | CMOS sink outputs (20 mA max.) |

4 Functional description

The STFPC320 integrates the supply standby management functionality, remote control decoder, a 28-bit VFD driver and a real-time clock (RTC). This device is meant to reduce the standby power consumption of the whole front panel application and also to reduce hardware/cost by integrating the above mentioned functions in a single chip.

By utilizing the standby function, the host processor and other ICs could be turned off, thus reducing the system power consumption. The STFPC320 is able to wake-up the system when programmed hotkeys are detected to signal that the full operation of the system is required. The hotkeys could be entered to the system through the front panel keys or through the infrared (IR) remote control. STFPC320 supports multiple remote control protocols decoding by setting the appropriate register.

The integrated 28-bit VFD driver can drive up to 16 digits of display. Controlling of the display is done through writing to a internal RAM. The 4 LED drivers allow indication of operation of the system. 2-wire serial interface (I²C) completes the interfacing part between host processor and STFPC320.

The STFPC320 integrates a a low-power serial RTC with a built-in 32.768kHz oscillator (external crystal controlled). Eight bytes of the SRAM are used for the clock/calendar function and are configured in binary coded decimal (BCD) format. An additional 12 bytes of SRAM provide status/ control of alarm, watchdog and square wave functions. Addresses and data are transferred serially via a two line, bidirectional I²C interface. The built-in address register is incremented automatically after each WRITE or READ data byte.

Functions available to the user include a non-volatile, time-of-day clock/calendar, alarm interrupts, watchdog timer and programmable Square Wave output. The eight clock address locations contain the century, year, month, date, day, hour, minute, second and tenths/hundredths of a second in 24 hour BCD format. Corrections for 28, 29 (leap year - valid until year 2100), 30 and 31 day months are made automatically.

4.1 Reset

Reset is an active low input signal to the STFPC320. A negative pulse input on RESET_N pin resets the STFPC320. Electrical specifications of this pin are identical to that of the logic input pin.

Upon power-up, an internal power on reset circuit resets the whole chip. This occurs when V_{DD} is ramping up (at approximately 2.7 V) and the whole chip is initialized within 4 μs. This time is much lesser than the typical V_{DD} ramp-up time. It is recommended to tie the RESET_N pin permanently by a pull-up resistor to V_{DD} if reset to STFPC320 is not desired during normal operation. For an initialization on power-up, a power-on-reset in STFPC320 is sufficient to reset the entire STFPC320.

As soon as the 3.3 V supply to the chip is stable, the I²C bus of the STFPC320 is ready for communication.

4.2 Cold boot up

When power is first applied to the system, the STFPC320 will be reset. It will then manage the power to the main board by bringing the STBY pin to a low level. This will wake-up the main processor which will assert the READY pin to a high level to indicate to STFPC320 of a proper boot-up sequence.

If the microprocessor does not assert the READY pin to a high within 10s, the STFPC320 will cut off the power to the Host by asserting the STBY pin. The high level on READY pin signifies that the processor is ready. After this, the processor can configure the STFPC320 by sending the various I²C commands for configuration of display, RC protocol, RTC display mapping, hot-keys.

The power-up behavior in 2 conditions is shown in the [Figure 4](#).

Figure 4. Power-up behaviour

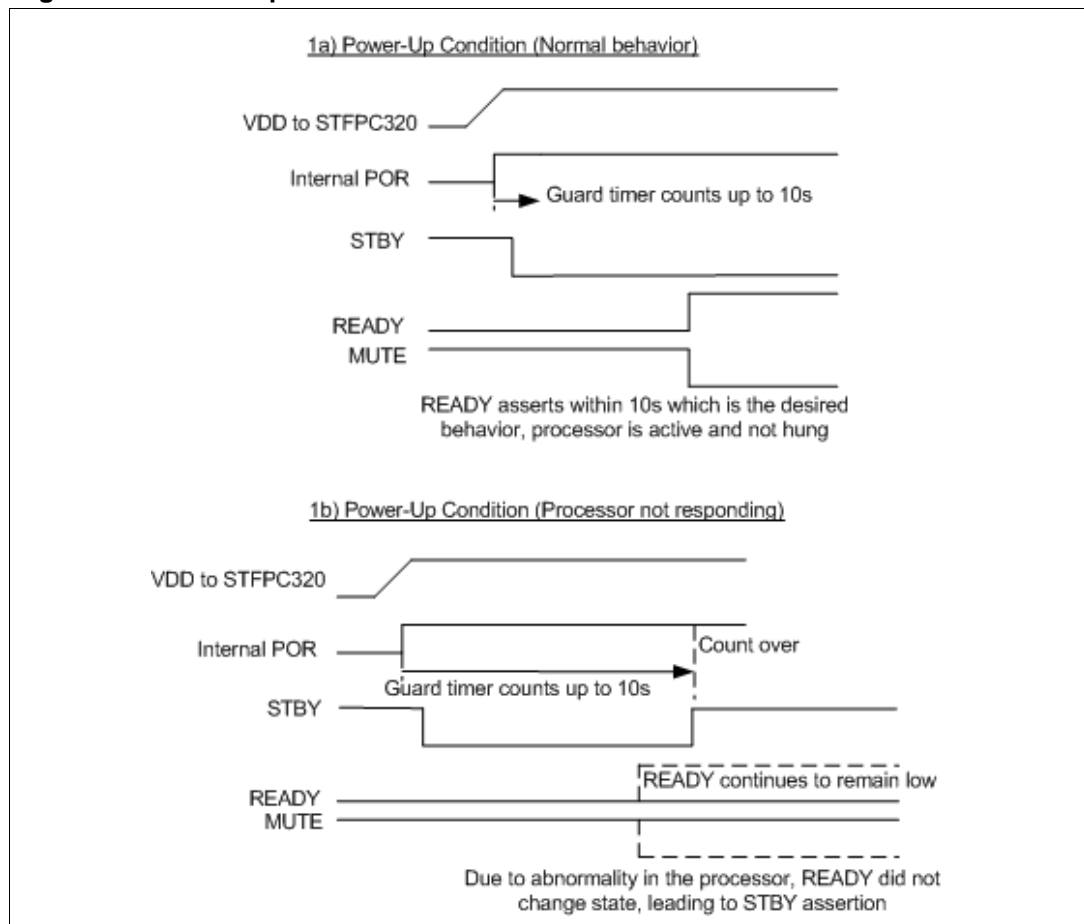

- Note:
- 1 Guard timer is turned off by default upon READY assertion.
 - 2 If the guard timer is to be kept on during READY high condition, the guard timer registers must be set accordingly by proper commands through I²C bus.
 - 3 In this power-up condition, the guard timer is triggered by internal POR pulse.
 - 4 During power-up, the guard timer value is 10s.

4.3 Entering standby mode

The STFPC320 will control the power to the main board using the STBY pin. During normal operation, the STBY pin is at a low level which externally controls a power MOS switch to enable power to the main board. The STFPC320 asserts the STBY pin to a high when any one of the following conditions occur:

- Processor fails to respond by enabling the READY pin within 10 s upon first power-up (cold boot up)
- Guard timer counts down to 0 s
- Processor makes the READY pin to low (can happen in various conditions, such as user presses STBY key on front panel, STBY key on remote control, etc.)

Figure 5. Standby mode behaviour

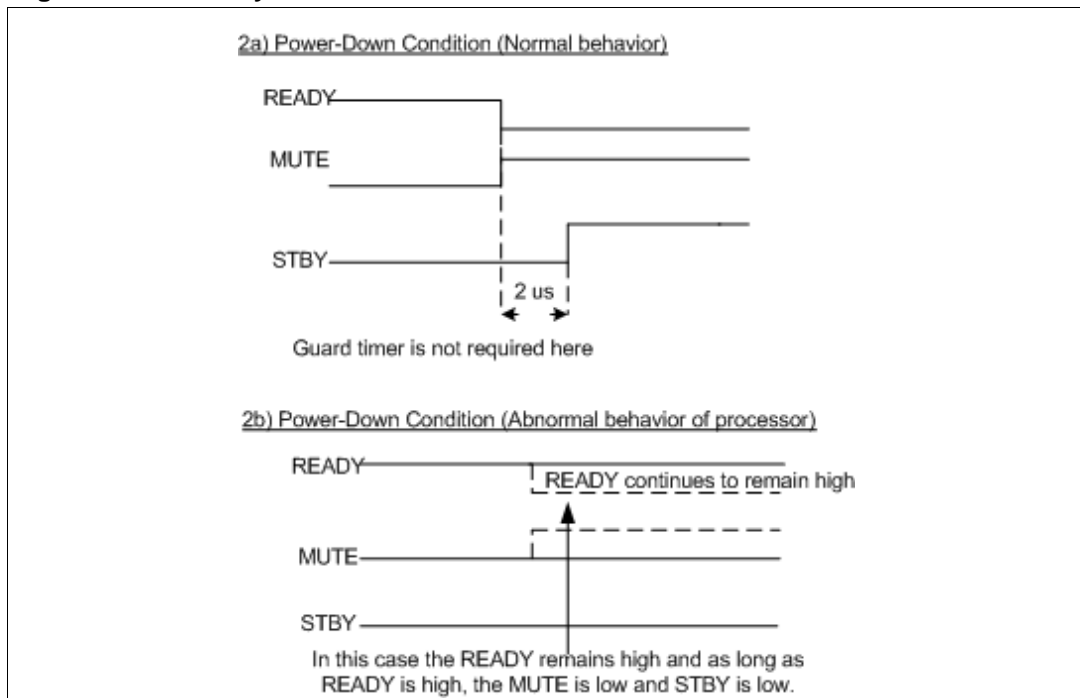

- Note:**
- 1 Guard timer can be kept on during normal condition when READY is high (depending on the user).
 - 2 In this condition, the guard timer can be disabled or enabled. If the guard timer is enabled, the timer needs to be cleared before the programmed count of the timer is reached. If the programmed count is reached, the STBY will be asserted.
 - 3 It is advisable not to enable the guard timer during normal operation.

4.4 Wake-up

The STFPC320 can wake-up from any one of the following sources:

- Front-panel keys
- Remote-control keys
- Real-time clock (RTC) in 3 conditions (alarm, watchdog timer, oscillator fail)
- External pin PIN_AV8 (only by a low-to-high transition on this pin)

Figure 6. Wake-up

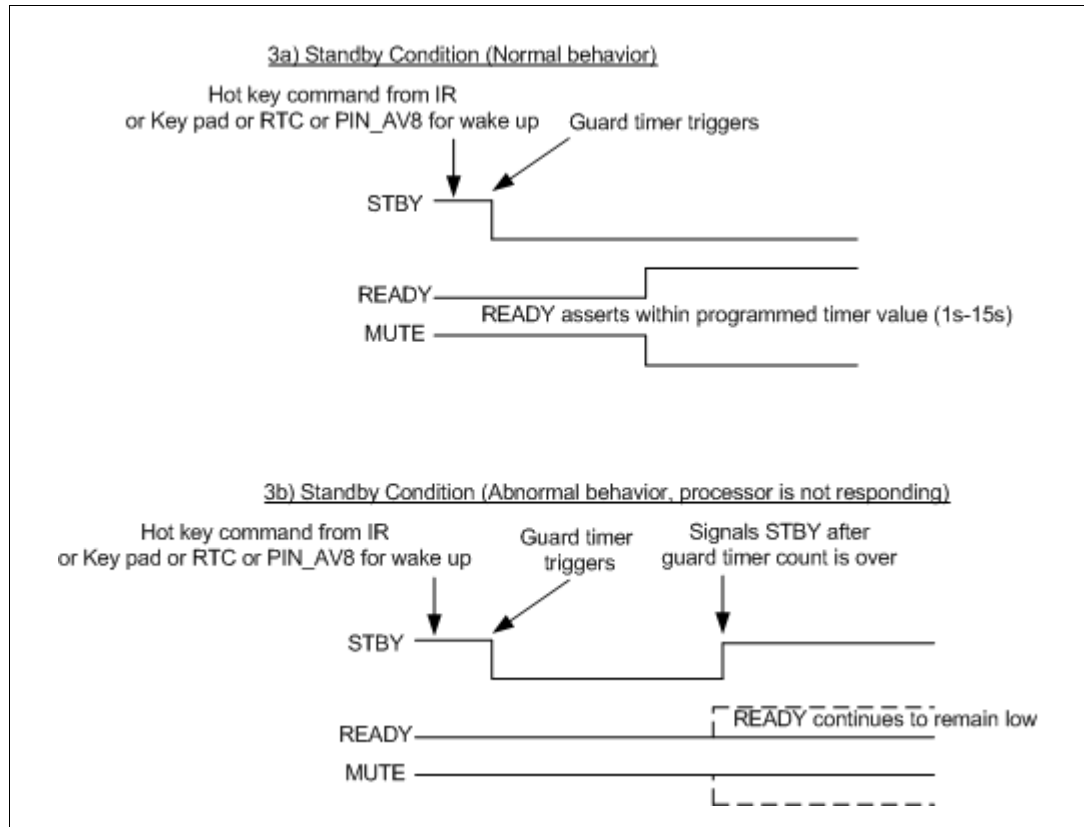

- Note:
- 1 When the hot-key is detected either from front-panel or remote control or RTC or from a low-to-high transition on PIN_AV8 pin during standby, the STBY pin de-asserts.
 - 2 The de-assertion of the STBY triggers the guard timer.
 - 3 The timer value is the programmed value by the user (1-15s). If the user did not change the value before entering standby, then it remains 10s.
 - 4 Also note that the guard timer is off when the STFPC320 is in the standby mode.

Guard timer is thus triggered by a de-assertion of the STBY signal or by internal power on reset signal.

4.5 Interrupts/events handling by STFPC320

The STFPC320 interrupts the Host by pulling the IRQ_N/SQW pin to a low-level both in normal mode of operation and during wake-up. The interrupt is enabled by STFPC320 when any of the conditions occur:

- Front panel key press in normal operation or during system standby state
- Remote control key press in normal operation or during system standby state
- A low-to-high transition on the external pin, PIN_AV8
- Real-time clock triggers (alarm, watchdog timer, oscillator fail)

The IRQ_N/SQW is an active low level signal and is cleared only after the interrupt buffer is read. After reading the interrupt buffer, the Host will know the actual source of the interrupt. This allows the Host to exactly know the event which caused the interrupt (e.g STBY key on the front panel). The interrupt signal is used to inform the Host of any events detected by the STFPC320. Note that the IRQ_N/SQW pin is an open-drain pin which requires an external pull-up resistor.

Figure 7. Interrupts/events handling

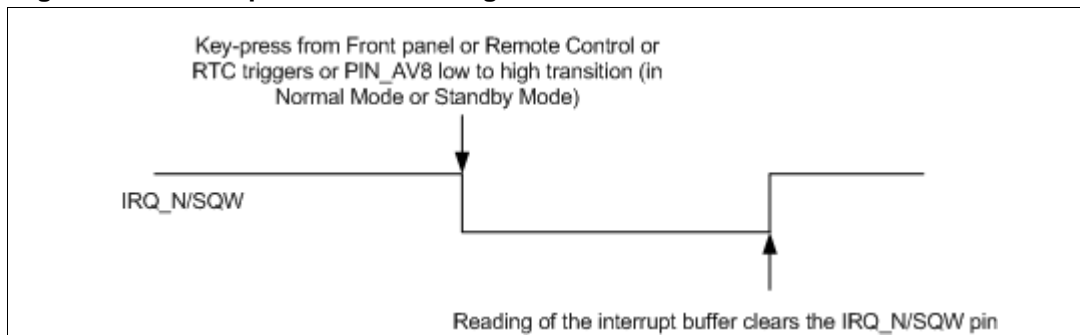

4.6 Ready pin

The STFPC320 supports cutting-off power to the main board for standby operation for good power management. STBY will be set to high when the READY transitions from high to low. During a cold boot up or wakeup from standby, if the READY pin stays low, the STFPC320 will assert the STBY when the guard timer has finished counting down to 0.

When the READY drops to a low, MUTE goes high immediately and soon after (2 μ s) the STBY is asserted.

In the normal mode of operation, when READY is a high, the STBY is asserted only when the guard timer is enabled and has finished counting down to 0. This is meant to put the system into standby as the READY pin was stuck at high and the guard timer register was not cleared before it finished counting down to 0. It is advised to disable the guard timer during normal operation.

4.7 Mute pin

The MUTE pin is set to logic high to mute the audio output before power is cut to the host processor. In wakeup mode, the MUTE pin is set to logic low to enable the audio output immediately after the high assertion of the READY pin. In general, MUTE follows READY pin with an inverted polarity. This pin is used to prevent pop-up sound during power-up and power-down states.

4.8 Keyscan matrix/front panel keys

The key scan matrix on the STFPC320 helps to pass command from the front panel to the host processor through the SDA pin on STFPC320. The STFPC320 can be programmed to wake-up the system from standby using any of the 24 keys pressed on the front panel. These wake-up keys are also referred to as hot-keys.

4.9 LED ports

4 LED displays are supported by the STFPC320. Turning on or off of the LED is done by issuing write command to the LED port. After reset, the LEDs are off. Note that the LED outputs sink the current, so the cathode of the diode must be connected to the LED pins of STFPC320.

4.10 Display

The display is divided into two sections, Normal and real-time clock (RTC).

4.10.1 Normal display

The VFD display is configurable for displays from 8 digits/20 segments to 16 digits/12 segments. The VFD display can be configured to be either in the normal VFD mode or in the RTC mode. In the normal VFD mode, the display shows whatever is written in the VFD display memory.

If the user desires to show normal display simultaneously with the RTC, then CPU must read the time of RTC display memory and then write all the data to be displayed to the normal display memory. After writing the values to the display memory, a display-on command will show both the normal and RTC display on the front panel.

On first power on, the default configuration is 16-digit, 12-segment mode (with display turned OFF).

4.10.2 RTC display

In RTC mode, the display can be configured to show the time in two modes, either by direct mapping of RTC to the display or by using the CPU. If CPU is used, the CPU reads the RTC value from RTC registers and then writes the time to be displayed in the RTC display memory.

4.11 Remote control decoder

Remote control (RC) decoder module decodes the signal coming from IR_DATA_IN. The list of IR remote control protocols recognized by STFPC320 is Philips RC-5, SONY, NEC, Thomson-RCA, Thomson-R2000 and Matsushita. The selection of remote control protocol to use is done by setting the RC Protocols register. The commands from RC is used to wake-up from standby and resume normal operation. All RC keys can be programmed to act like RC hotkeys. Upon receiving any one of the designated hotkeys, wake-up operation will begin.

4.12 PIN_AV8

External device (e.g. set-top box) could pull this pin high to wake-up the system. A low-to-high transition on this pin will signal the STFPC320 to wake-up and provide power to the system. This signal is considered high when it is in the range of 2.5 - 3.6 V (proper voltage division must be done externally so that the STFPC320 PIN_AV8 sees no more than 3.6 V). No action is taken on the high-to-low transition on PIN_AV8. Also when the pin is already a high, the current state of the system is maintained and it does not trigger anything.

4.13 Default state upon power-up

The [Table 3](#) below shows the default state of the STFPC320 upon power-up.

Table 3. Default state

| S.No. | Functions | Default state |
|-------|----------------------|---------------------------------|
| 1 | Display | OFF |
| 2 | Key-scan | ON |
| 3 | IR (Remote Control) | ON |
| 4 | Display mode | 12 segment/16 digit |
| 5 | Display address | 10H with Address increment mode |
| 6 | RC protocol | RC-5 (Raw format) |
| 7 | LED | OFF |
| 8 | Dimming | 1/16 duty factor |
| 9 | Hot Keys (IR and FP) | Disabled |
| 10 | Guard timer | 10s |

4.14 Initial state

On power application, the 1/16-pulse width is set and the display shows the value configured in the VFD display RAM before entering the standby mode. Thus if HELLO is required to be shown on the VFD upon wake-up, then the user must write the corresponding digit and segments locations in the VFD display memory before going into the standby mode of operation. Note that the V_{SS} must be present in order to keep the VFD display active. The value of the display changes only after user configuration.

If the user wishes to display the RTC value during standby, then the user must configure the STFPC320 by sending the appropriate command. If the user does not configure the STFPC320 to display the RTC in standby, the VFD shows the same value as was written in the VFD display memory location.

Note that all the hot keys are disabled on power-up. Only the hotkeys (FP or RC) or RTC or the low to high transition on the PIN_AV8 pin can be detected to wake-up the system from standby condition.

5 Operating state diagram

Figure 8. Operating state diagram

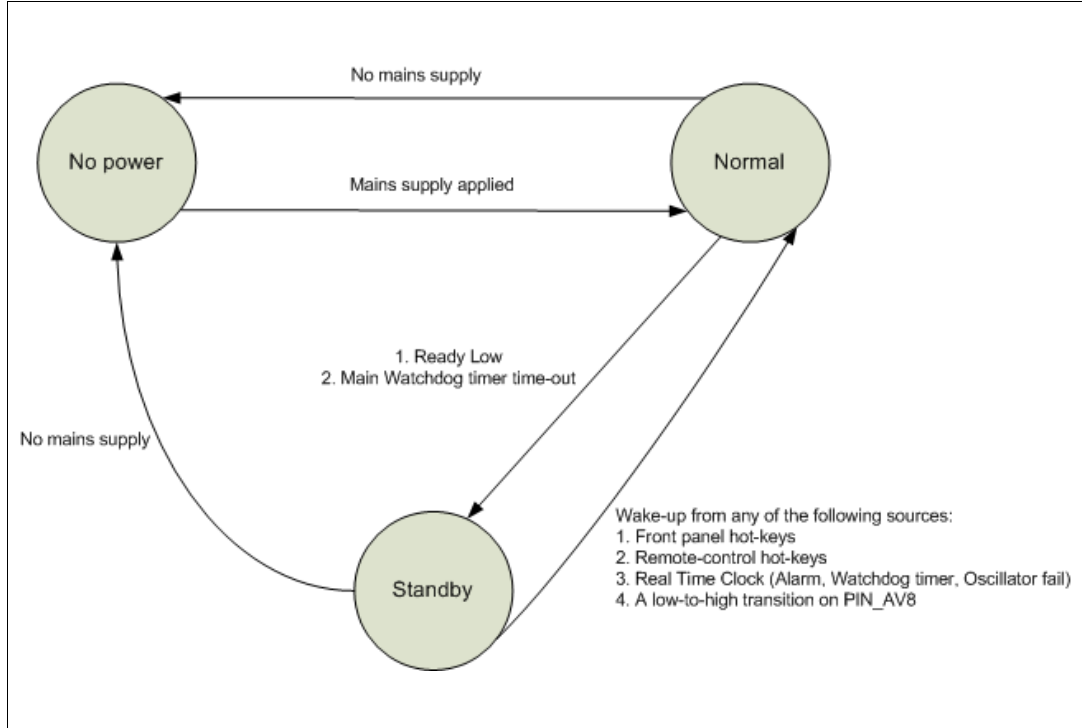

6 Real-time clock (RTC) operation

6.1 Real-time clock

The RTC operates as a slave device through the slave address of the STFPC320 on the serial bus. Access is obtained by implementing a start condition followed by the correct slave address (Write: 0x52H and Read: 0x53H). The 16 bytes contained in the device can then be accessed sequentially in the following order:

1. Reserved
2. Seconds register
3. Minutes register
4. Hours register
5. Square wave/day register
6. Date register
7. Century/month register
8. Year register
9. Calibration register
10. Watchdog register
- 11 - 15. Alarm registers
16. Flags register

6.2 2-wire bus characteristics

The bus is intended for communication between different ICs. It consists of two lines: a bidirectional data signal (SDA) and a clock signal (SCL). Both the SDA and SCL lines must be connected to a positive supply voltage (typical voltage is 3.3 V) via a pull-up resistor (typical value is 10 K). The following protocol has been defined:

- Data transfer may be initiated only when the bus is not busy.
- During data transfer, the data line must remain stable whenever the clock line is High.
- Changes in the data line, while the clock line is High, will be interpreted as control signals.

Accordingly, the following bus conditions have been defined:

- **Bus not busy:** both data and clock lines remain High.
- **Start data transfer:** a change in the state of the data line, from high to Low, while the clock is High, defines the START condition.
- **Stop data transfer:** a change in the state of the data line, from Low to High, while the clock is High, defines the STOP condition.
- **Data Valid:** the state of the data line represents valid data when after a start condition, the data line is stable for the duration of the high period of the clock signal. The data on the line may be changed during the Low period of the clock signal. There is one clock pulse per bit of data.
Each data transfer is initiated with a start condition and terminated with a stop

condition. The number of data bytes transferred between the start and stop conditions is not limited. The information is transmitted byte-wide and each receiver acknowledges with a ninth bit.

By definition a device that gives out a message is called “transmitter,” the receiving device that gets the message is called “receiver.” The device that controls the message is called “master.” The devices that are controlled by the master are called “slaves.”

- **Acknowledge:** each byte of eight bits is followed by one Acknowledge Bit. This Acknowledge Bit is a low level put on the bus by the receiver whereas the master generates an extra acknowledge related clock pulse. A slave receiver which is addressed is obliged to generate an acknowledge after the reception of each byte that has been clocked out of the master transmitter.

The device that acknowledges has to pull down the SDA line during the acknowledge clock pulse in such a way that the SDA line is a stable Low during the High period of the acknowledge related clock pulse. Of course, setup and hold times must be taken into account. A master receiver must signal an end of data to the slave transmitter by not generating an acknowledge on the last byte that has been clocked out of the slave. In this case the transmitter must leave the data line High to enable the master to generate the STOP condition.

Figure 9. Serial bus data transfer sequence

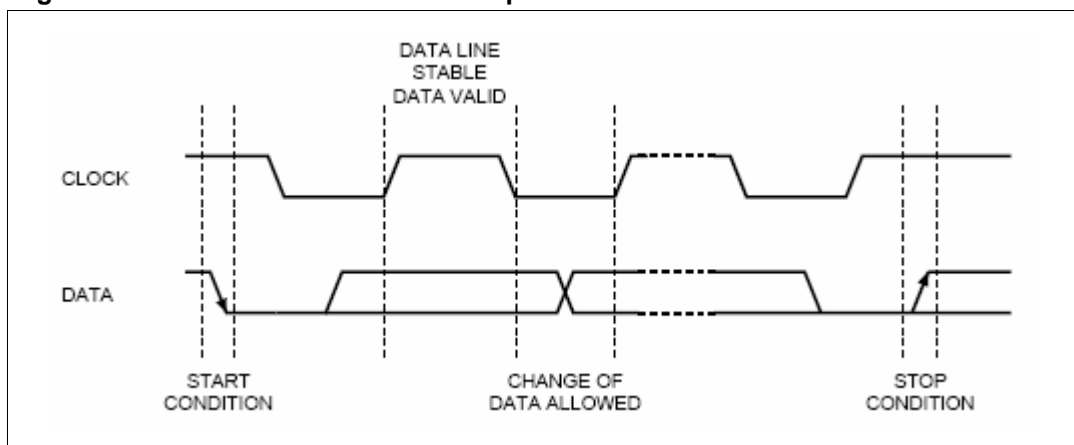
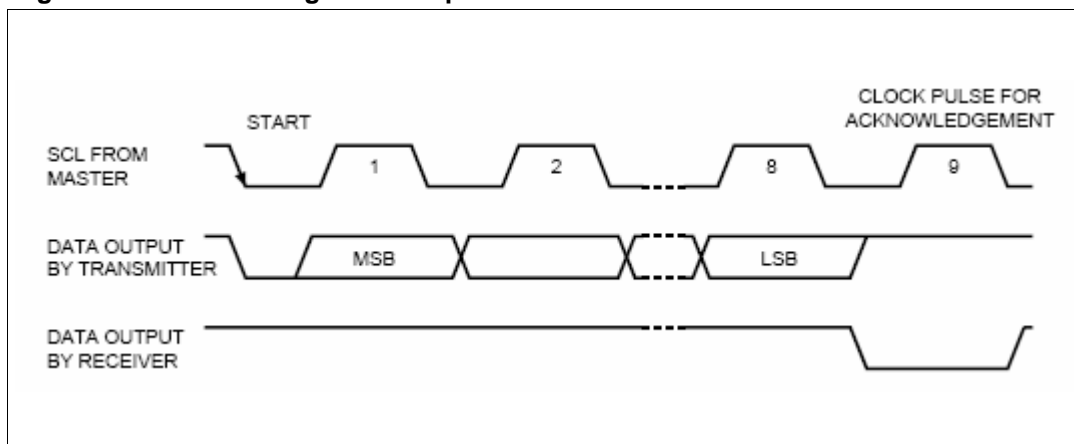

Figure 10. Acknowledgement sequence



6.3 Watchdog timer

The watchdog timer can be used to detect an out of control microprocessor. The user programs the watchdog timer by setting the desired amount of time-out into the Watchdog Register, address 09h. Bits BMB4-BMB0 store a binary multiplier and the three bits RB2-RB0 select the resolution where:

- 000 = 1/16 second (16Hz)
- 001 = 1/4 second (4Hz)
- 010 = 1 second (1Hz)
- 011 = 4 seconds (1/4Hz)
- 100 = 1 minute (1/60Hz)

*Note: Invalid combinations (101, 110, and 111) do NOT enable a watchdog time-out. Setting the BMB4-BMB0 = 0 with any combination of RB2-RB0, other than 000, will result in an immediate watchdog time-out. The amount of time-out is then determined to be the multiplication of the five-bit multiplier value with the resolution. (For example: writing 00001110 in the Watchdog register = 3*1 or 3 seconds). If the processor does not reset the timer within the specified period, the STFPC320 generates a watchdog output pulse on the IRQ_N/SQW pin.*

The watchdog timer can only be reset by having the microprocessor perform a WRITE of the Watchdog register. The time-out period then starts over. Should the watchdog timer time-out, any value may be written to the Watchdog Register in order to clear the IRQ_N/SQW pin. A value of 00h will disable the watchdog function until it is again programmed to a new value. A READ of the Flags Register will reset the Watchdog flag (Bit D7; Register 0Fh). The watchdog function is automatically disabled upon power-up, and the Watchdog Register is cleared.

6.4 Real-time clock (RTC)

The RTC keeps track of the date and time. Once the date and time are set, the clock works when the STFPC320 is in normal operation and standby operation. The wake-up alarm feature is included in the RTC module. The accuracy of the RTC is approximately 10 ppm (± 25 secs/month).

The wakeup alarm is programmed to wake up once the date and time set are met. This feature is present in normal and standby mode of operation. Only one date and time is available for setting.

The real-time clock (RTC) uses an external 32.768 kHz quartz crystal to maintain an accurate internal representation of the second, minute, hour, day, date, month, and year. The RTC has leap-year correction. The clock also corrects for months having fewer than 31 days.

6.4.1 Reading the real-time clock

The real-time clock (RTC) is read by specifying the address corresponding to the register of the real-time clock and then initiating a Read command. The RTC registers can then be read in a sequential read mode. Since the clock runs continuously and a read takes a finite amount of time, there is the possibility that the clock could change during the course of a read operation. In this device, the time is latched by the read command (falling edge of the clock on the ACK bit prior to RTC data output) into a separate latch to avoid time changes during the read operation. The clock continues to run. Alarms occurring during a read are unaffected by the read operation.

6.4.2 Writing to the real-time clock

The time and date may be set by writing to the RTC registers. To avoid changing the current time by an uncompleted write operation, the current time value is loaded into a separate buffer at the falling edge of the clock on the ACK bit before the RTC data input bytes, the clock continues to run. The new serial input data replaces the values in the buffer. This new RTC value is loaded back into the RTC register by a stop bit at the end of a valid write sequence. An invalid write operation aborts the time update procedure and the contents of the buffer are discarded. After a valid write operation the RTC will reflect the newly loaded data beginning with the next "one second" clock cycle after the stop bit is written. The RTC continues to update the time while an RTC register write is in progress and the RTC continues to run during any nonvolatile write sequences. A single byte may be written to the RTC without affecting the other bytes.

6.5 Register table for RTC

Table 4. Register table for RTC

| Addr | D7 | D6 | D5 | D4 | D3 | D2 | D1 | D0 | Function/range BCD format | |
|------|----------|------------------|------------|-------------|------------------------|-------------|-----|-----|---------------------------|-----------|
| 00h | Reserved | | | | Reserved | | | | - | - |
| 01h | ST | 10 seconds | | | Seconds | | | | Seconds | 00-59 |
| 02h | OFIE | 10 minutes | | | Minutes | | | | Minutes | 00-59 |
| 03h | 0 | 0 | 10 hours | | Hours (24-hour format) | | | | Hours | 00-23 |
| 04h | RS3 | RS2 | RS1 | RS0 | 0 | Day of week | | | Day | 01-7 |
| 05h | 1 | 0 | 10 date | | Date: day of month | | | | Date | 01-31 |
| 06h | CB0 | CB1 | 0 | 10M | Month | | | | Century/month | 0-3/01-12 |
| 07h | 10 Years | | | | Year | | | | Year | 00-99 |
| 08h | 1 | 0 | S | Calibration | | | | | Calibration | |
| 09h | RB2 | BMB4 | BMB3 | BMB2 | BMB1 | BMB0 | RB1 | RB0 | Watchdog | |
| 0Ah | AFE | SQWE | 1 | AI 10M | Alarm month | | | | AI month | 01-12 |
| 0Bh | RPT4 | RPT5 | AI 10 date | | Alarm date | | | | AI date | 01-31 |
| 0Ch | RPT3 | 0 | AI 10 Hour | | Alarm Hour | | | | AI hour | 00-23 |
| 0Dh | RPT2 | Alarm 10 minutes | | | Alarm minutes | | | | AI min | 00-59 |
| 0Eh | RPT1 | Alarm 10 seconds | | | Alarm seconds | | | | AI sec | 00-59 |
| 0Fh | WDF | AF | 0 | 0 | 0 | Flags | | | | |

Keys: S = sign bit

ST = stop bit

OFIE = oscillator fail interrupt enable bit

BMB0 – BMB4 = watchdog multiplier bits

CEB = century enable bit

CB = century bit

OUT = output level

SQWE = square wave enable bit

AFE = Alarm flag enable flag

RS0-RS3 = SQW frequency bits

RB0 – RB2 = watchdog resolution bits

RPT1 – RPT5 = alarm repeat mode bits

WDF = watchdog flag (read only)

AF = alarm flag (read only)

OF = Oscillator fail bit

It is recommended to fill the unused bits in the register map to '0' upon a cold boot up.

6.6 Setting alarm clock registers

The address locations 0Ah-0Eh contain the alarm settings. The alarm can be configured to go off at a prescribed time on a specific month, date, hour, minute, or second or repeat every year, month, day, hour, minute, or second. It can also be programmed to go off while the STFPC320 is in the standby mode to serve as a system wake-up call.

The bits RPT5-RPT1 put the alarm in the repeat mode of operation. [Table 5](#) shows the possible configurations. Codes not listed in the table default to the once per second mode to quickly alert the user of an incorrect alarm setting.

When the clock information matches the alarm clock settings based on the match criteria defined by RPT5-RPT1, the AF (Alarm Flag) is set. If AFE (alarm flag enable) is also set (and SQWE is '0.'), the alarm condition activates the IRQ_N/SQW pin.

Note: Note that by default, the alarm repeat mode is enabled and by default the repeat frequency is set to “once per year”.

Note: If the address pointer is allowed to increment to the flag register address, an alarm condition will not cause the Interrupt/Flag to occur until the address pointer is moved to a different address. It should also be noted that if the last address written is the “Alarm Seconds,” the address pointer will increment to the Flag address, causing this situation to occur.

The IRQ_N/SQW output is cleared by a READ to the flags register as shown in [Figure 11](#). A subsequent READ of the flags register is necessary to see that the value of the alarm flag has been reset to '0'.

Figure 11. Alarm interrupt reset waveform

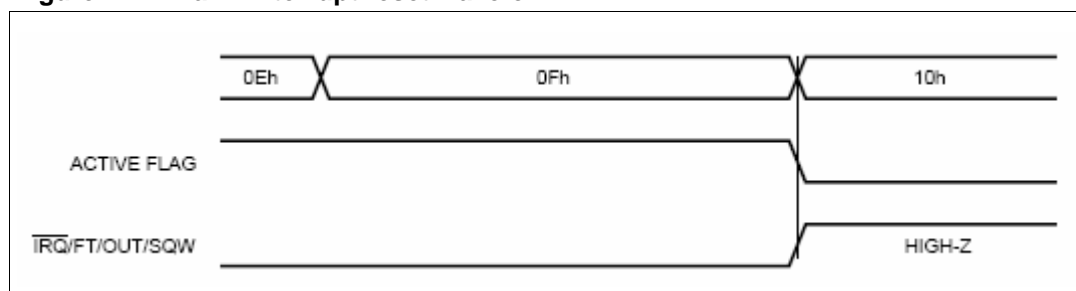

Table 5. Alarm repeat modes

| RPT5 | RPT4 | RPT3 | RPT2 | RPT1 | Alarm settings |
|------|------|------|------|------|-----------------|
| 1 | 1 | 1 | 1 | 1 | Once per second |
| 1 | 1 | 1 | 1 | 0 | Once per minute |
| 1 | 1 | 1 | 0 | 0 | Once per hour |
| 1 | 1 | 0 | 0 | 0 | Once per day |
| 1 | 0 | 0 | 0 | 0 | Once per month |
| 0 | 0 | 0 | 0 | 0 | Once per year |

Note: The “Once Per Year” is the default.

6.7 Calibrating the clock

The STFPC320 is driven by a quartz controlled oscillator with a nominal frequency of 32.768 kHz. The accuracy of the RTC depends on the frequency of the quartz crystal that is used as the time-base for the RTC. The accuracy of the clock is dependent upon the accuracy of the crystal, and the match between the capacitive load of the oscillator circuit and the capacitive load for which the crystal was trimmed. The STFPC320 crystal is designed for use with a 6 pF crystal load capacitance. When the calibration circuit is properly employed, accuracy improves to better than ± 2 ppm at 25 deg C.

The oscillation rate of crystals changes with temperature. Therefore, the STFPC320 design employs periodic counter correction. The calibration circuit adds or subtracts counts from the oscillator divider circuit at the divide by 256 stage. The number of times pulses which are blanked (subtracted, negative calibration) or split (added, positive calibration) depends upon the value loaded into the five calibration bits found in the calibration register. Adding counts speeds the clock up, subtracting counts slows the clock down.

The calibration bits occupy the five lower order bits (D4-D0) in the calibration register (08h). These bits can be set to represent any value between 0 and 31 in binary form. Bit D5 is a sign bit; '1' indicates positive calibration and '0' indicates negative calibration. Calibration occurs within a 64-minute cycle. The first 62 minutes in the cycle may, once per minute, have one second either shortened by 128 or lengthened by 256 oscillator cycles. If a binary '1' is loaded into the register, only the first 2 minutes in the 64 minute cycle will be modified; if a binary 6 is loaded, the first 12 will be affected, and so on.

Therefore, each calibration step has the effect of adding 512 or subtracting 256 oscillator cycles for every 125,829,120 actual oscillator cycles, that is +4.068 or -2.034 PPM of adjustment per calibration step in the calibration register.

Assuming that the oscillator is running at exactly 32.768 KHz, each of the 31 increments in the calibration byte would represent +10.7 or -5.35 seconds per day which corresponds to a total range of +5.5 or -2.75 minutes per month.

Two methods are available for ascertaining how much calibration a given STFPC320 may require:

- The first involves setting the clock, letting it run for a month and comparing it to a known accurate reference and recording deviation over a fixed period of time. Calibration values, including the number of seconds lost or gained in a given period allows the designer to give the end user the ability to calibrate the clock as the environment requires, even if the final product is packaged in a non-user serviceable enclosure. The designer could provide a simple utility that accesses the calibration byte.
- The second approach is better suited to a manufacturing environment, and involves the use of IRQ_N/SQW pin. This pin will toggle at 512Hz when RS3 = '0', RS2 = '1', RS1 = '1', RS0 = '0', SQWE = '1' and ST = '0'. In normal mode, it is always advised to keep the SQWE to a '0'.

Any deviation from 512 Hz indicates the degree and direction of oscillator frequency shift at the test temperature. For example, a reading of 512.010124 Hz would indicate a +20ppm oscillator frequency error, requiring a -10 (XX001010) to be loaded into the Calibration Byte for correction. Note that setting or changing the calibration byte does not affect the frequency test or square wave output frequency.

Figure 12. Crystal accuracy across temperature

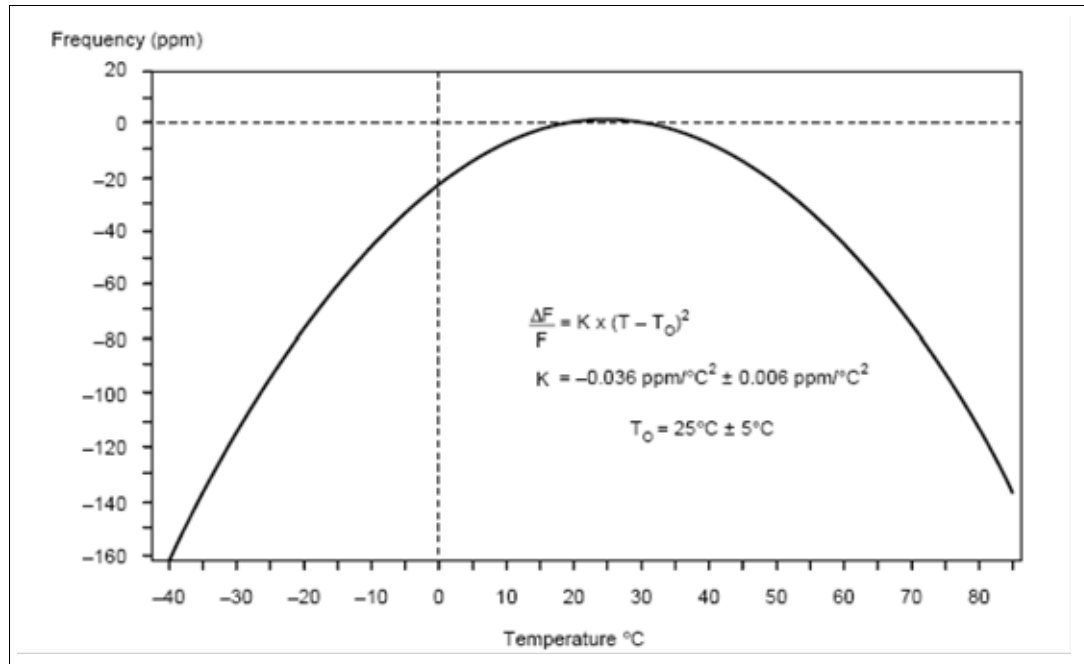
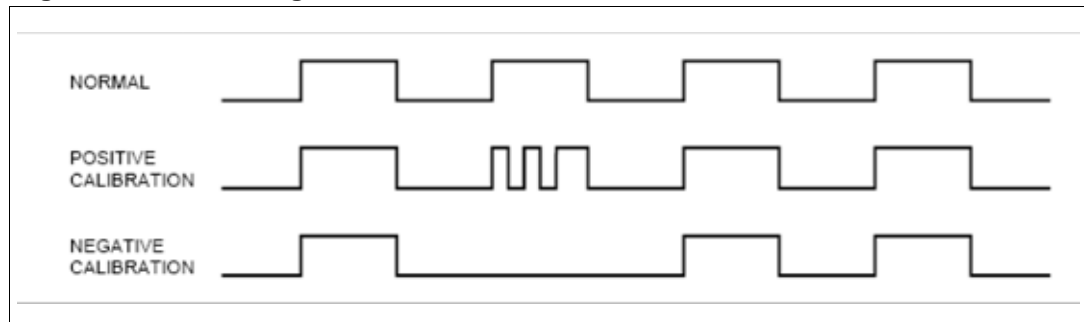

Figure 13. Calibrating waveform



6.8 Square wave output

The STFPC320 offers the user a programmable square wave function which is output on the IRQ_N/SQW pin. RS3-RS0 bits located in 04h register establish the square wave output frequency. These frequencies are listed in [Table 6](#). Once the selection of the SQW frequency has been completed, the IRQ_N/SQW pin can be turned on or off under software control with the square wave enable bit (SQWE) located in register 0Ah. The initial power-up default for the IRQ_N/SQW output is 32 KHz.

Table 6. Square wave output frequency

| Square wave bits | | | | Square wave | |
|------------------|-----|-----|-----|-------------|-------|
| RS3 | RS2 | RS1 | RS0 | Frequency | Units |
| 0 | 0 | 0 | 0 | None | - |
| 0 | 0 | 0 | 1 | 32.768 | kHz |
| 0 | 0 | 1 | 0 | 8.162 | kHz |
| 0 | 0 | 1 | 1 | 4.096 | kHz |
| 0 | 1 | 0 | 0 | 2.048 | kHz |
| 0 | 1 | 0 | 1 | 1.024 | kHz |
| 0 | 1 | 1 | 0 | 512 | Hz |
| 0 | 1 | 1 | 1 | 256 | Hz |
| 1 | 0 | 0 | 0 | 128 | Hz |
| 1 | 0 | 0 | 1 | 64 | Hz |
| 1 | 0 | 1 | 0 | 32 | Hz |
| 1 | 0 | 1 | 1 | 16 | Hz |
| 1 | 1 | 0 | 0 | 8 | Hz |
| 1 | 1 | 0 | 1 | 4 | Hz |
| 1 | 1 | 1 | 0 | 2 | Hz |
| 1 | 1 | 1 | 1 | 1 | Hz |

6.9 Century bits

These two bits will increment in a binary fashion at the turn of the century, and handle all leap years correctly. See [Table 7](#) below for additional explanation.

Table 7. Century bits

| CB1 | CB0 | Leap Year? | Example ⁽¹⁾ |
|-----|-----|------------|------------------------|
| 0 | 0 | Yes | 2000 |
| 0 | 1 | No | 2100 |
| 1 | 0 | No | 2200 |
| 1 | 1 | No | 2300 |

1. Leap year occurs every four years (for years evenly divisible by 4), except for years evenly divisible by 100. The only exceptions are those years evenly divisible by 400 (the year 2000 was a leap year, year 2100 is not).

6.10 Oscillator stop detection

If the oscillator fail (OF) bit is internally set to a '1', this indicates that the oscillator has either stopped, or was stopped for some period of time and can be used to judge the validity of the clock and date data. This bit will be set to '1' any time the oscillator stops.

In the event the OF bit is found to be set to '1' at any time other than the initial power-up, the STOP bit (ST) should be written to a '1', then immediately reset to a '0'. This will restart the oscillator.

The following conditions can cause the OF bit to be set:

- The first time power is applied (defaults to a '1' on power-up).

Note: If the OF bit cannot be written to '1' four (4) seconds after the initial power-up, the STOP bit (ST) should be written to a '1', then immediately reset to a '0'.

- The voltage present on Vcc is insufficient to support oscillation.
- The ST bit is set to a '1'.
- External interference of the crystal

If the oscillator fail interrupt enable bit (OFIE) is set to a '1', the IRQ_N/SQW pin will also be activated. The IRQ_N/SQW output is cleared by resetting the OFIE or OF bit to '0' (NOT by reading the Flag register).

The OF bit will remain set to '1' until written to logic '0'. The oscillator must start and have run for at least 4 seconds before attempting to reset the OF bit to '0'. If the trigger event occurs during the power-down condition, this bit will be set correctly.

6.11 Initial power-on defaults

Upon application of power to the device, the register bits in the RTC will initially power-on in the state indicated in [Table 8](#).

Table 8. Initial power-on default values of the registers

| ST | OF | OFIE | OUT | AFE | SQWE | RS3-1 | RS0 | Watchdog |
|----|----|------|-----|-----|------|-------|-----|----------|
| 0 | 1 | 0 | 1 | 0 | 0 | 0 | 1 | 0 |

Note: All other control bits power-up in an undetermined state. The user should write the OF bit to a 0 after 4s (after the oscillator has started up and the clock is stable). If the OFIE is to be enabled, then write a '1' to the OFIE bit in the RTC register.

7 Commands

A command sets the display mode and status of the VFD driver.

The first 1 byte input to the STFPC320 through the SDA pin after the slave address is regarded as a command. If slave address is not transmitted before the commands/data are transmitted, the commands/data being transmitted are invalid (however, the commands/data already transmitted remain valid).

7.1 Configuration mode setting command

This command initializes the STFPC320 and performs any one of the following functions:

1. Selects the number of segments and number of grids (1/8 to 1/16 duty, 12 segments to 20 segments). When this command is executed, display is turned off. To resume display, the display ON command must be executed. If the same mode is selected, nothing is performed.
2. Selects the remote control protocol to use.
3. Sets the guard timer. The guard timer is configurable from 1 to 15s or turned off completely.
4. Sets the guard timer action to perform when the guard timer counts. Two actions are allowed: no action, set STBY to high level.

| | | | | | | | | |
|-----|---|----|----|----|----|----|----|-----|
| MSB | | | | | | | | LSB |
| 0 | 0 | b5 | b4 | b3 | b2 | b1 | b0 | |

Description: Bits b7-b6 = 00 is decoded as a configuration mode setting command. The subsequent bits are decoded as follows:

b5: Reserved

b4: Normal display setting

b3: RTC display setting (during normal or STBY modes)

b2: enables all RC keys as hot-keys

b1: Reserved

b0: enables the guard timer to issue STBY

Note: *When displaying the RTC during normal mode, if the μP is writing data to STFPC320 using I²C bus, the RTC display on VFD momentarily turns OFF.*

The first byte after the configuration command is in the following format:

Figure 14. First byte format after configuration byte

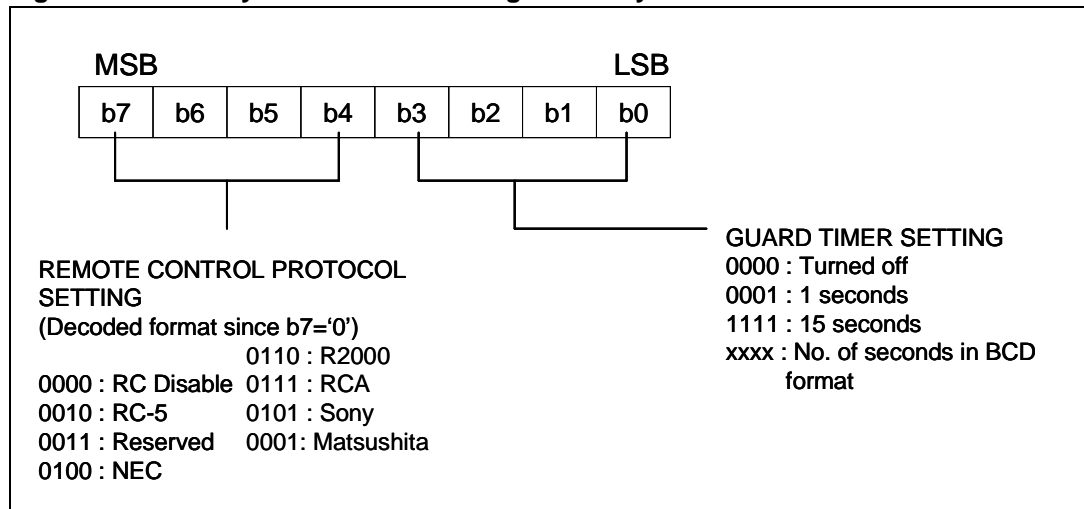

When b7 = '0', incoming RC data is output on SDA in **decoded format** where the Device Address, Start Bit, Toggle Bit and Data Bits are sent. Note that the default location is 0x00 for the first device address. This order of the bits sent is in the same format as the incoming RC data.

When b7 = '1', incoming **raw data** (no header information) is output on SDA. Address decoding is still performed to decode the corresponding RC protocol. The format of the data on SDA corresponds to the format of the respective RC frame.

For details, refer to the RC protocol section of the datasheet.

Upon power application, the following modes are selected:

- Normal display setting: 16-digit, 12-segment mode is selected (default: display off and keyscan on).
- Remote control protocol setting: RC-5 with raw format.
- Guard timer setting: turned on with 10s. After the first command is processed by STFPC320, the guard timer is turned off until it is turned on by the host.
- Guard timer action: issue standby.

The second byte after the configuration command is in the format displayed in [Figure 15](#)

Figure 15. Second byte format after configuration type

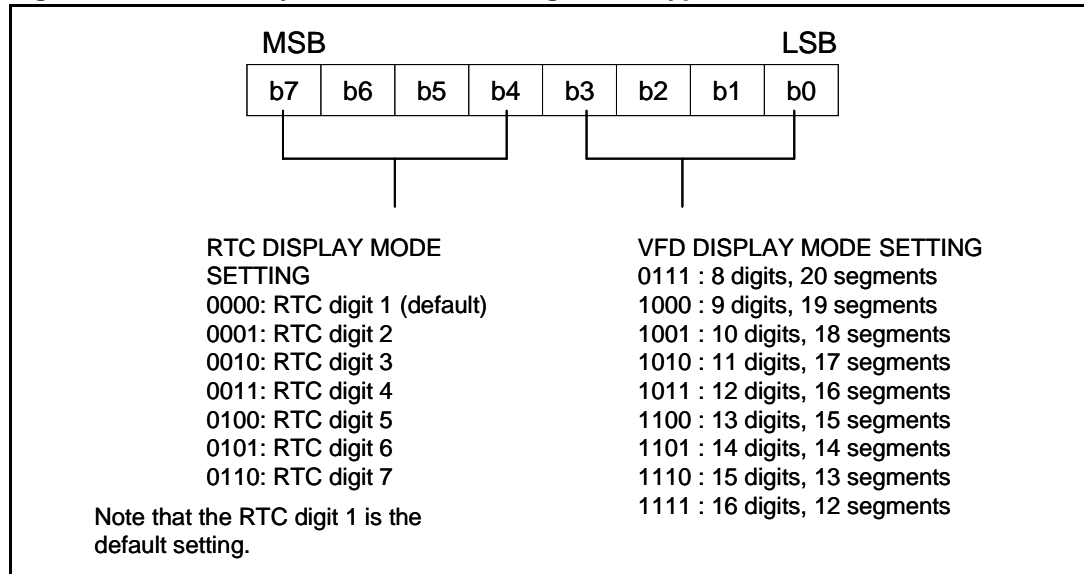

| | | | | | | | | | |
|-------|-------|-------|-------|-------|-------|-------|-------|-------|--------|
| H | H | M | M | S | S | | | | |
| Dig 1 | Dig 2 | Dig 3 | Dig 4 | Dig 5 | Dig 6 | Dig 7 | Dig 8 | Dig 9 | Dig 10 |

The above example shows the HH, MM, SS digits on a 10-digit display panel when RTC digit 1 is configured (Bits b7 - b4= "0000") & HH:MM:SS format is selected with separator being a part of the same digit. The MSB of Hour corresponds to Digit 1 when b7 - b4= "0000".

When b7-b4="0001" is configured, the MSB of Hour starts from the Digit 2.

Note: The Digit 1 must start from the left.

7.2 Data setting command

This command sets the data-write and data-read modes.

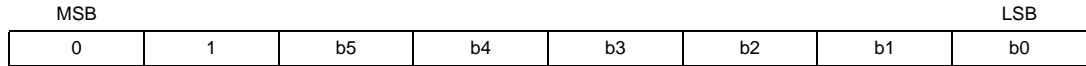

Description: Bits b7-b6 = 01 is decoded as a data setting command. The subsequent bits are decoded as follows:

- b5 b4 = 00: data write command (see bits b1-b0)
- b5 b4 = 10: data read 1 command (see bits b1-b0)
- b5 b4 = 11: data read 2 command (see bits b1-b0)
- b5 b4 = 01: reserved
- b3: clear the guard timer (no change in guard time)
- b2: '1' implies fixed address of display RAM/ '0' implies auto increments the address after data has been written.

Table 9. Data write command. b5 b4: 00

| b1-b0 | |
|-------|---|
| 00 | Write memory (display or RTC) – See Note Note: on page 37 |
| 01 | Enter Test mode (only used for production test) Do not use this in normal operation. |
| 10 | Clear Test mode Do not use this in normal operation. |
| 11 | Write LED (see Section 9: LED port on page 44) |

Table 10. Data read 1 command. b5 b4: 10

| b1-b0 | |
|-------|--|
| 00 | Read Key (Section 8: Key matrix on page 42) |
| 01 | Read Switch + Address Pointer (see Section 10: SW data on page 45) |
| 10 | Read RC data (following two bytes are the address + command from RC); Refer to Section 15: Remote control protocols on page 51 |
| 11 | Read Interrupt (refer to Section 14: Interrupt flags on page 50) |

Table 11. Data read 2 command. b5 b4: 11

| b1-b0 | |
|-------|---|
| 00 | Reserved |
| 01 | Read Configuration (see Section 13: Configuration data on page 48) |

Table 11. Data read 2 command. b5 b4: 11

| | |
|----|---|
| 10 | Reserved |
| 11 | Read RTC Registers (see Section 11.1: RTC display data read on page 46) |

On power application, the normal display mode and address increment mode is set with the default display memory address set to 10H.

In the auto increment address mode, the address command is sent only once followed by the data bytes.

Note: This command is seldom used. For writing to memory (normal or RTC), the address setting command is sufficient.

7.3 Display control and hotkey setting command

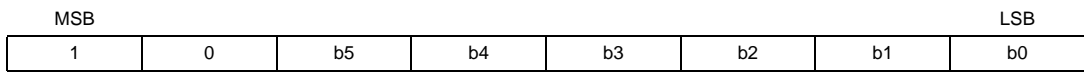

Description: Bits b7-b6 = 10 is decoded as a display control and hotkey setting command. The subsequent bits are decoded as follows:

b5 = 0: sets display control for dimming setting as shown in the table on the next page.

When b5 = 1, the decoding is based on bits b2-b0 as illustrated below:

b2 b1 b0 = XX1: RC hotkeys and address configuration.

b2 b1 b0 = X1X: front panel hotkeys configuration.

b2 b1 b0 = 1XX: sets the RTC segments location. Refer to the table below for the configuration.

b4, b3: reserved (the bits can be set to '0')

Note: XXX on the bit values means don't care. The bits can be set to '0'.

| | RTC segments configuration | Remote control hotkeys |
|--|---|--|
| <p>When b5 = 0</p> <p>b2.b0: Sets dimming quantity. 000: Sets pulse width to 1/16. 001: Sets pulse width to 2/16. 010: Sets pulse width to 4/16. 011: Sets pulse width to 10/16. 100: Sets pulse width to 11/16. 101: Sets pulse width to 12/16. 110: Sets pulse width to 13/16. 111: Sets pulse width to 14/16.</p> <p>b3: Turns on/off display 0: Display off (key scan continues) 1: Display on</p> | <p>When b5 = 1</p> <p>b2 b1 b0: 1XX</p> <p>This command is followed by sending 7 bytes of configuration data for RTC segments (byte1-6) and format configuration (byte7).</p> <p>Read 12.3.1 for details.</p> | <p>When b5 = 1</p> <p>b2 b1 b0: XX1</p> <p>Following this command is 16bytes configuration data for 8 RC hotkeys configuration.</p> <p>Read 12.3.3 for details.</p> <p>Front panel hotkeys</p> <p>When b5 = 1</p> <p>b2 b1 b0: X1X</p> <p>This command is followed by sending 3 bytes (24 keys) of configuration data to set any key as hotkey.</p> <p>Read <i>Section : Thus, if the a segment is located on segment 1, the bits b3-b0 are "0000". If b segment is located on segment 2, the bits b3-b0 are "0001" and so on. on page 39</i> for details.</p> |

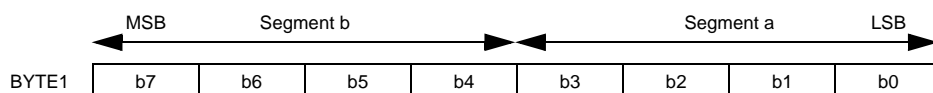

Description: Byte2 to byte6 will follow the same pattern as shown for byte1 above:

- BYTE2: segment d, segment c
- BYTE3: segment f, segment e
- BYTE4: segment m, segment g
- BYTE5: segment k, segment h
- BYTE6: segment p/col, segment j/col

Segments r and n are never used for RTC display.

Byte7 is for RTC format configuration:

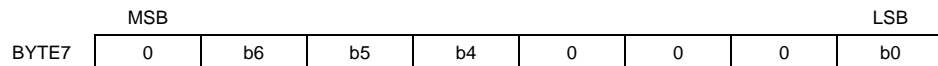

When b6 is set to a '0', it implies that the dot point/column is a part of the same digit as the LSB of the HH or LSB of the MM. When b6 is set to a '1', it means that a separate digit is used for the separator between the hour/minute and minute/second.

When b5 is set to a '0', HH:MM display format of RTC is chosen and when it is set to a '1', the HH:MM:SS format is chosen.

When b4 is set to a '0', the AM/PM is not displayed and when it is set to a '1', the AM/PM is displayed on the VFD.

Figure 16. 14-segment + dotpoint display

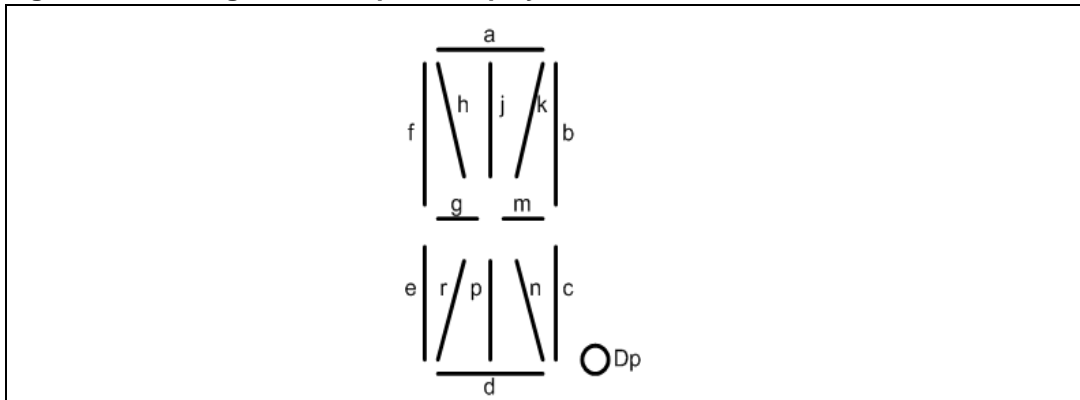

For a display with segment configuration as in [Figure 16](#), the location of "a" segment represented by bits b3-b0 corresponds to "0000". Location of b segment corresponds to "0001". Location of c segment corresponds to "0010" and so on.

Thus, if the a segment is located on segment 1, the bits b3-b0 are "0000". If b segment is located on segment 2, the bits b3-b0 are "0001" and so on.

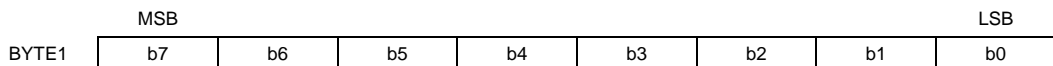

- Description:**
- b0: KS1 KEY1
 - b1: KS1 KEY2
 - b2: KS2 KEY1
 - b3: KS2 KEY2

- b4: KS3 KEY1
- b5: KS3 KEY2
- b6: KS4 KEY1
- b7: KS4 KEY2

Byte2 and Byte3 follow the same pattern as above for the hotkey configuration. To select any one of the key as hotkey, the bit value is set to '1'.

Figure 17. Front panel hotkeys configuration

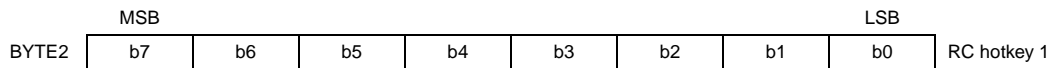
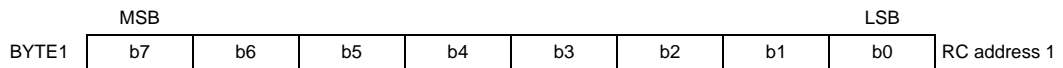
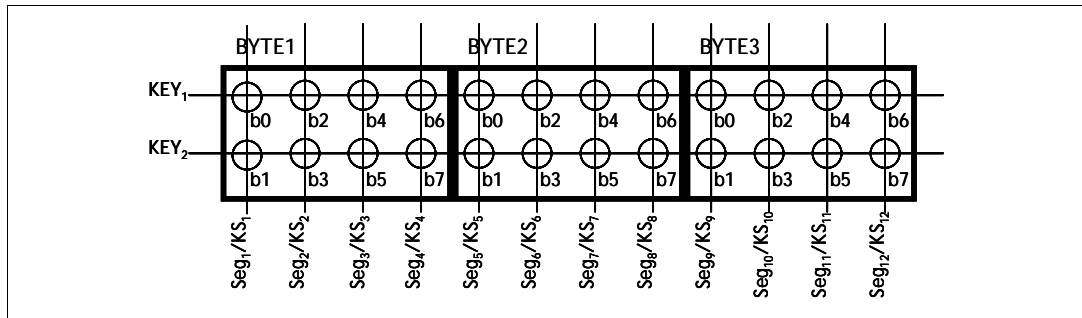

Description:

To configure an RC hotkey two bytes are required. The first byte is used to specify the RC address and the second byte is used to specify the hotkey command. Hence there is the option of having 8 hotkeys from the same RC address or one hotkey each for 8 different RC address.

- byte1, byte2: RC hotkey1
- byte3, byte4: RC hotkey2
- byte5, byte6: RC hotkey3
- byte7, byte8: RC hotkey4
- byte9, byte 10: RC hotkey5
- byte11, byte12: RC hotkey6
- byte13, byte14: RC hotkey7
- byte15, byte16: RC hotkey8

If less than 8 RC hotkeys are required, there is no need to fill all the 16 bytes. The number of configuration bytes sent will depends on how many hotkeys.

For example, to configure 2 hotkeys from 2 different RC addresses for Philips RC-5 protocol:

Philips RC-5 Device Address: XXX00001, Hot Key 1: XX000001

Philips RC-5 Device Address: XXX01100, Hot Key 2: XX000010

Note: For RC protocols, where the MSB does not end on the 8-bit, the data is configured starting from b0 (LSB) to the MSB.

7.4 Example for device configuration

After the proper power-up sequence, an example for configuration of the STFPC320 is given below:

1. Configuring display & RC

0x09 = RTC display & enables the guard timer to issue STBY
0xAA = raw format, RC-5 protocol, 10s for initial guard time value
0x0A = digit 1 will show the Hour MSB, 11 digits/17 segments display

2. Configure RTC segments

0xA4 = display control command with RTC segments configuration
0x10, 0x32, 0x54, 0x76, 0xAB, 0xEE = 6 bytes used to map the segment locations for RTC
0x20 = format of RTC (separator a part of same digit, HH: MM: SS format with no AM/PM)

3. Configure front panel keys as wake-up keys (hotkeys)

0xA2 = hotkey setting command for front panel keys. Subsequent 3 bytes are used to configure the desired front panel keys to be wake-up keys as described in Section [Section](#) : *Thus, if the a segment is located on segment 1, the bits b3-b0 are "0000". If b segment is located on segment 2, the bits b3-b0 are "0001" and so on. on page 39.*

4. Configure RC keys as wake-up keys (hotkeys)

0xA1 = hotkey setting command for RC keys. For one hot key configuration from one RC device address, 2 bytes are sent (1st byte is RC address and 2 byte is hotkey command as described in [Section 7.3 on page 38](#)).

8 Key matrix

The key matrix is of 12 x 2 configuration, as shown below.

Figure 18. Key matrix and key-input data storage RAM

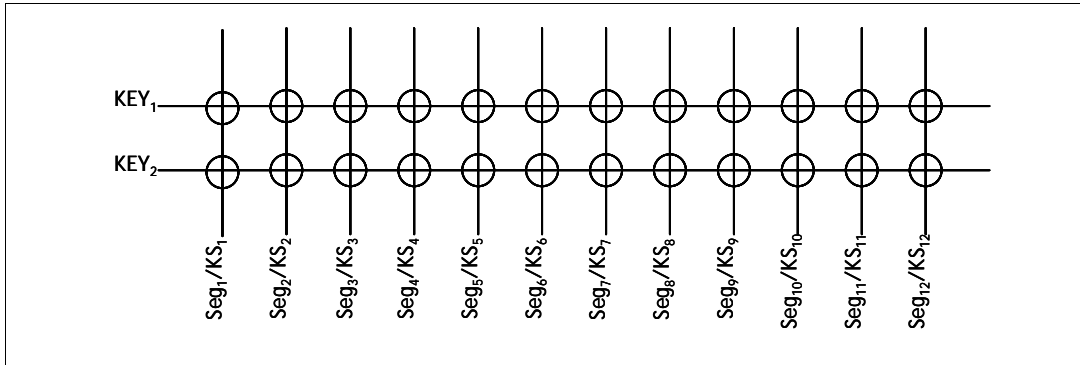

The data of each key is stored as illustrated below and is read by a read command, starting from the most significant bit.



8.1 Key read sequence

| | | | | | | | | |
|----------------------|-----|---|---|---|---|---|---|-----|
| | MSB | | | | | | | LSB |
| Data Setting Command | 0 | 1 | 1 | 0 | 0 | 0 | 0 | 0 |

| | | | | | | | | |
|-----------------|-----|----|----|----|----|----|----|-----|
| | MSB | | | | | | | LSB |
| Key Data Byte 1 | b7 | b6 | b5 | b4 | b3 | b2 | b1 | b0 |

| | | | | | | | | |
|-----------------|-----|----|----|----|----|----|----|-----|
| | MSB | | | | | | | LSB |
| Key Data Byte 2 | b7 | b6 | b5 | b4 | b3 | b2 | b1 | b0 |

| | | | | | | | | |
|-----------------|-----|----|----|----|----|----|----|-----|
| | MSB | | | | | | | LSB |
| Key Data Byte 3 | b7 | b6 | b5 | b4 | b3 | b2 | b1 | b0 |

Description: For example when the key corresponding to the KEY1/KS1 is pressed, the bit b0 of Byte 3 will be set. This is decoded as the key value connected to KEY1/KS1 which could be "PLAY" (for example). When the processor decodes the key value corresponding to the "PLAY" key, it takes the necessary action (e.g. play the disc).

Note: Upon a key-press, the IRQ_N/SQW pin will be asserted. The interrupt flag should be read to know the source of interrupt. The interrupt flag is read by sending the 0x63 command. As soon as the interrupt buffer is read, the IRQ_N/SQW pin will be de-asserted.

9 LED port

Data is written to the LED port by a write command, starting from the most significant bit of the port. When a bit of this port is set to 0, the corresponding LED lights up; when the bit is set to a 1, the LED turns off. The data of bits 5 through 8 are ignored. Upon first power-up, all the LEDs are turned OFF.

Figure 19. LED byte format

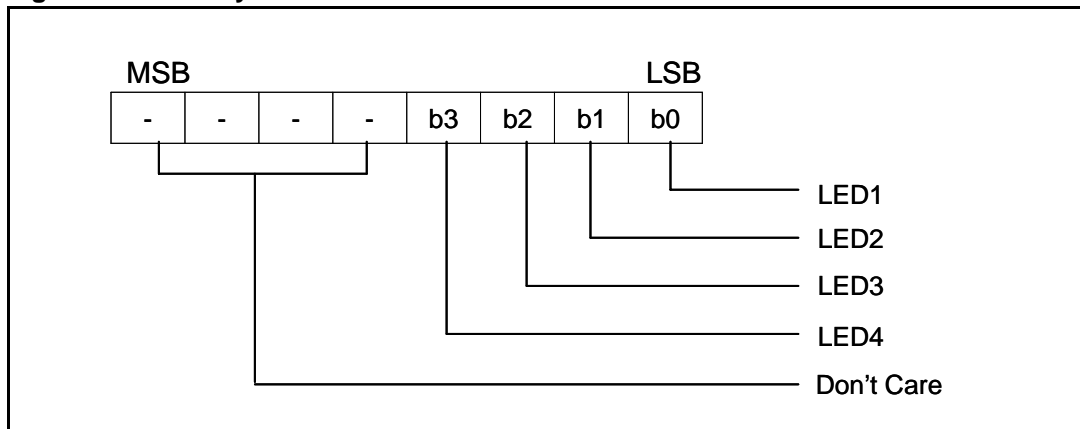

9.1 Writing to LED sequence

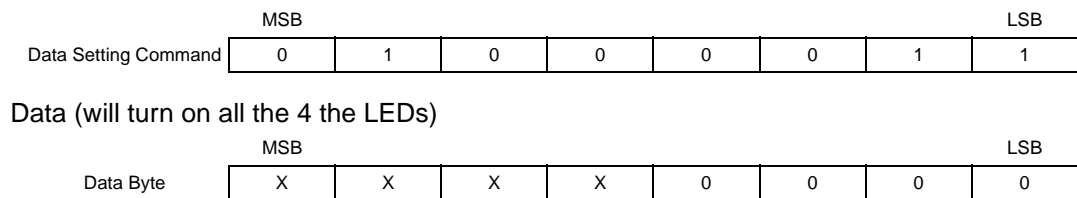

For example, the LEDs can be connected to indicate 'Power-On', 'Standby', 'Record', 'Function' status on front panel. If the data bit corresponding to the LED is a '0', the LED will turn-on during normal operation and standby mode.

So as an example, to turn on the LED for standby indication, the processor must write '0' to the corresponding data bit before de-asserting the READY pin (i.e. before going into STBY). This will continuously keep the STBY LED 'ON' during standby mode of operation.

10 SW data

The SW data are read by the appropriate read command, starting from the most significant bit. Bits 3 through 8 (b7-b2) represent the Address pointer for the internal RAM.

Figure 20. LED byte format

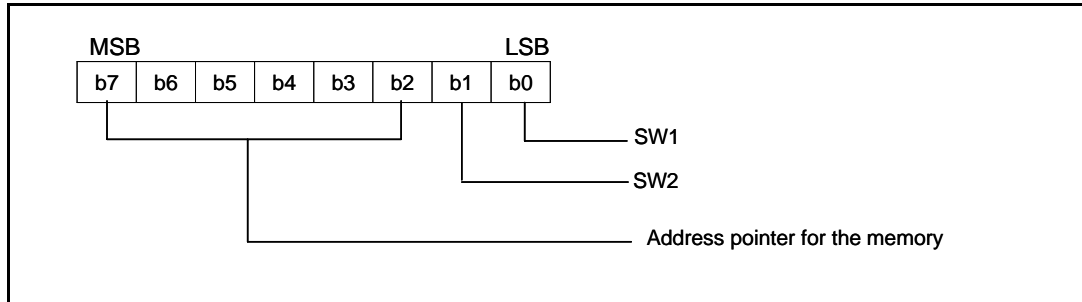

10.1 Reading switch sequence

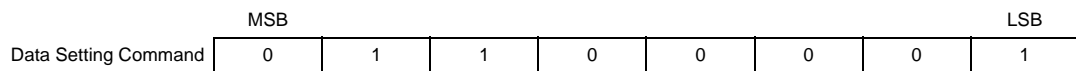

After sending this command, the STFPC320 will output a byte with the 2 bit values of the 2 switches and 6-bit address pointer values.

12 Normal display memory locations

Table 12. Display RAM address and display mode

| Seg ₁ | Seg ₄ | Seg ₈ | Seg ₁₂ | Seg ₁₆ | Seg ₂₀ | |
|---|------------------|------------------|-------------------|-------------------|-------------------|-------------------------|
| 10 HL | 10 HU | | 11 HL | 11 HU | 12 HL | DIG₁ |
| 13 HL | 13 HU | | 14 HL | 14 HU | 15 HL | DIG₂ |
| 16 HL | 16 HU | | 17 HL | 17 HU | 18 HL | DIG₃ |
| 19 HL | 19 HU | | 1A HL | 1A HU | 1B HL | DIG₄ |
| 1C HL | 1C HU | | 1D HL | 1D HU | 1E HL | DIG₅ |
| 1F HL | 1F HU | | 20 HL | 20 HU | 21 HL | DIG₆ |
| 22 HL | 22 HU | | 23 HL | 23 HU | 24 HL | DIG₇ |
| 25 HL | 25 HU | | 26 HL | 26 HU | 27 HL | DIG₈ |
| 28 HL | 28 HU | | 29 HL | 29 HU | 2A HL | DIG₉ |
| 2B HL | 2B HU | | 2C HL | 2C HU | 2D HL | DIG₁₀ |
| 2E HL | 2E HU | | 2F HL | 2F HU | 30 HL | DIG₁₁ |
| 31 HL | 31 HU | | 32 HL | 32 HU | 33 HL | DIG₁₂ |
| 34 HL | 34 HU | | 35 HL | 35 HU | 36 HL | DIG₁₃ |
| 37 HL | 37 HU | | 38 HL | 38 HU | 39 HL | DIG₁₄ |
| 3A HL | 3A HU | | 3B HL | 3B HU | 3C HL | DIG₁₅ |
| 3D HL | 3D HU | | 3E HL | 3E HU | 3F HL | DIG₁₆ |
| b ₇ b ₄ b ₃ b ₀ | | | | | | |
| XX H _L XX H _U | | | | | | |
| Higher 4 bits | | Lower 4 bits | | | | |

Only the lower 4 bits of the addresses assigned to Seg₁₇ through Seg₂₀ are valid, the higher 4 bits are ignored.

Note that the common grid/segment outputs are grid-based. The grid has to be enabled before any segments can be turned on. If data is written for a segment before enabling the respective grid, nothing is present on the display.

13 Configuration data

To read the configuration data from STFPC320, 0x71 command ([Section 7.2: Data setting command on page 36](#)) is sent from the Host to STFPC320. After this, the STFPC320 will output a maximum of 14 bytes with the configuration data. The Host can choose to read only a few bytes by pulsing the SCL line according to the number of bytes to be read.

Up to a maximum of 14-bytes are sent from MSB to LSB as configuration data. The 14-bytes represent the following configuration information.

Figure 21. Configuration data bytes

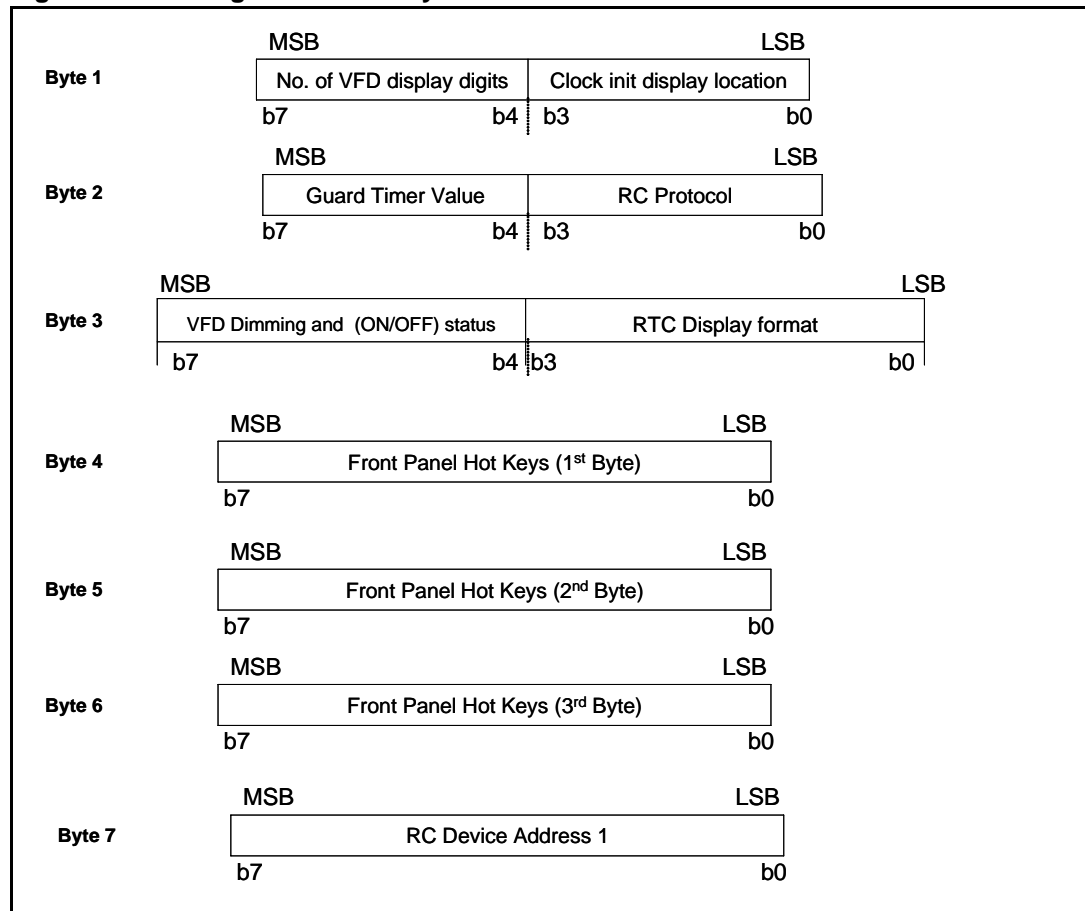
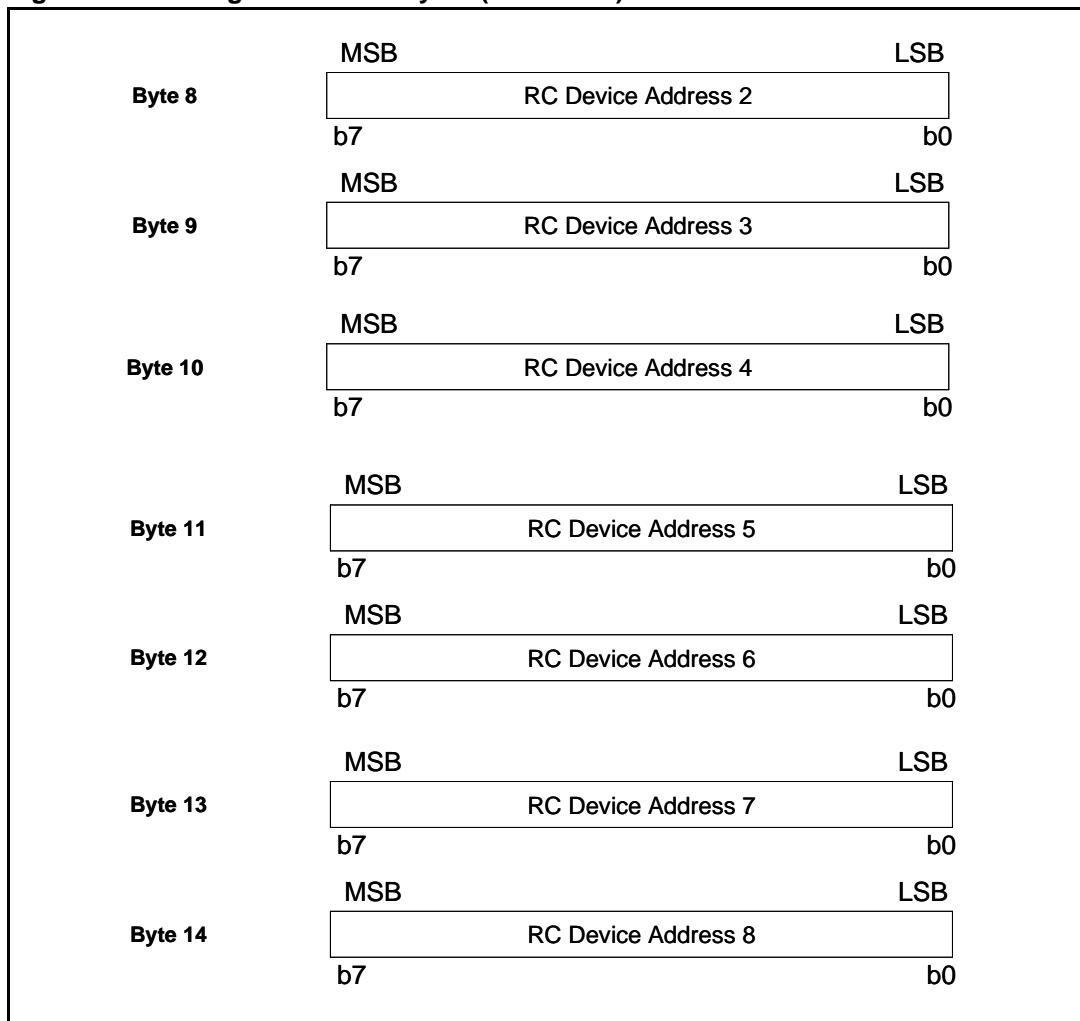

Figure 22. Configuration data bytes (continued)



14 Interrupt flags

The interrupt is sent on the IRQ_N/SQW pin when any one of the events occur: FP key pressed, RC key pressed, PIN_AV8 transitions to a high or RTC events (watchdog timer, alarm, oscillator fail). Simultaneously, the interrupt flags are set.

The micro-processor can read the interrupt flags by sending the "01100011" command. After decoding this command, STFPC320 output one byte data as described below to indicate the source of interrupt.

Figure 23. Interrupt byte format

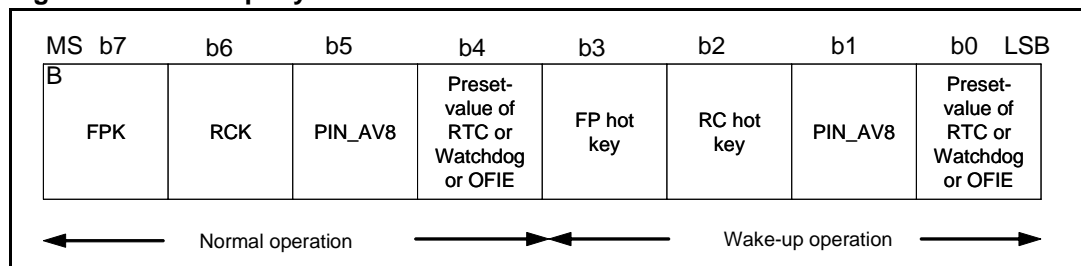

Note: Default value of the register is 00h.

Description: In the normal mode of operation (system is not in standby), the events described below will cause any of the b4 to b7 bit to be set to 1 and IRQ_N/SQW will be asserted low:

- b4: RTC events
- b5: PIN_AV8 transition to High
- b6: valid remote control key detection
- b7: front panel key detection

Having detected the assertion of IRQ_N/SQW pin, micro-processor should then read the interrupt buffer to determine the external event causing the interrupt. Once read, the buffer will be cleared and IRQ_N/SQW is released.

In the wake-up operation (system is in standby), the events described below will cause any of the b0 to b3 bit to be set to 1 and wakeup occurs (STBY output is set to low):

- b0: RTC events
- b1: PIN_AV8 transition to High
- b2: valid remote control hotkeys detection
- b3: front panel hotkeys detection

Once wakeup occurs, micro-processor should pull READY to high to indicate to STFPC320 of a proper boot-up. The STFPC320 will then assert the interrupt to indicate that an external event has been occurred. The microprocessor should then read the interrupt buffer to determine the event causing the wakeup.

When the interrupt is caused by the RTC, the microprocessor should read the RTC interrupt flag at address 0Fh to determine the specific RTC event: alarm, watchdog timer of RTC or oscillator fail.

15 Remote control protocols

15.1 Decoded and RAW formats

The main difference between decoded and raw remote-control format is that for decoded format, the STFPC320 sends the RC data only from RC device address matches 0 of the remote control protocol being used. Whereas for the raw format, the RC data is sent by STFPC320 from any device address of the particular remote control protocol being used.

If the STFPC320 is used to send RC data in decoded format in normal mode, it is advisable that the Host configure the STFPC320 to RC-raw format before entering the standby mode. This is to allow wakeup from multiple remote control device addresses of the remote control protocol (depending on the configuration as outlined in [Section : on page 40](#)). In the decoded RC format, the STFPC320 device wakes up the system from a single device address.

15.2 Sending IR data on I²C interface

The IR data is sent on the SDA pin of the I²C interface when the microprocessor issues an IR data read command (0x62, [Section 7.2: Data setting command on page 36](#)). The data is sent in the decoded format or the raw format depending on the user configuration.

In general, the data is sent on SDA pin in byte format with MSB transmitted first as shown in [Figure 24](#).

Figure 24. IR data format

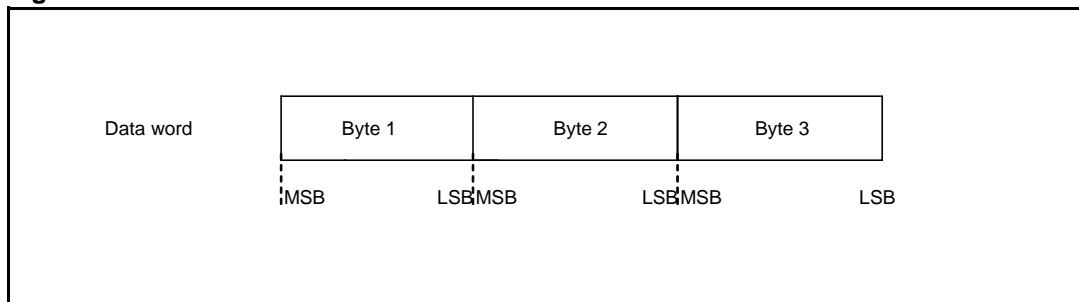

15.3 Philips RC-5 remote control protocol

The RC-5 remote control protocol is based on bi-phase (aka Manchester) coding as shown in [Figure 25](#). Note that the coding is on the transmitted side. The data on IR_DATA_IN pin of the STFPC320 after reception by the photo diode will be inverted of below. The MSB is transmitted first.

Figure 25. Bi-phase coding

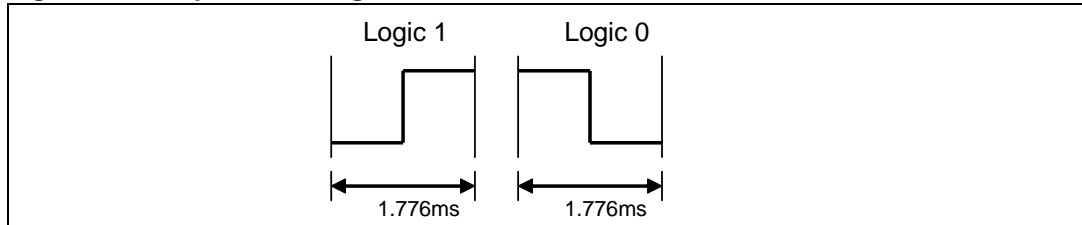

Figure 26. RC-5 protocol frame

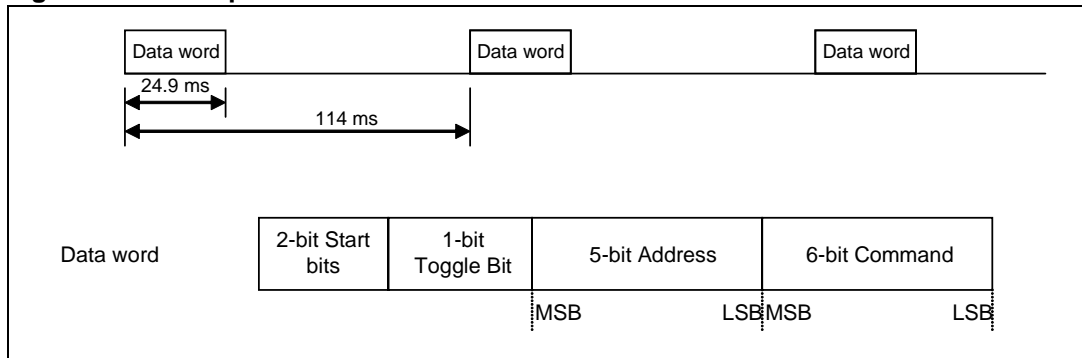
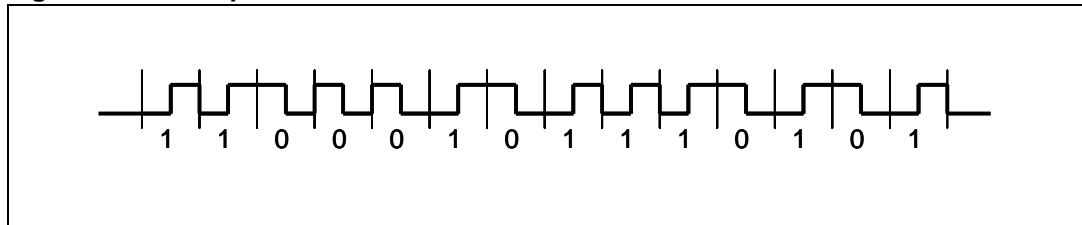

Figure 27. Example of RC-5 transmission



For RC 5 data transmission, a binary 1 is represented by a low to high transition and a binary 0 is represented by a high to low transition from the IR transmitter.

The first two start bits (S1 and S2) are sync bits. For normal operation, they are always set to “11” on the transmit side. After the photo-diode, there is one inversion. So the data at the IR_DATA_IN of the STFPC320 will be inverted of above. The next bit is the toggle bit. This bit is inverted each time a key on the remote control is pressed. Bits A1..A5 are the address bits. The address bits indicate the intended application that the remote control protocol is used for. Bits C1..C6 are the command bits. The command bits instruct what action is to be taken.

15.3.1 RC-5 data in decoded format

In the decoded form, the ADR bits followed by Start bit and Toggle Bit followed by Data bits are sent in this order for each remote control protocol. The number of bits depends on the corresponding RC protocol. The remaining empty bits are stuffed with 1's to complete a byte-aligned data frame.

Example for Philips RC-5 protocol, if the 5-bit ADDR field is "00000" and 6-bit command is "000001", the in decoded format the data on SDA pin will be sent as follows with MSB transmitted first. S stands for Start Bit and T stands for Toggle Bit.

Figure 28. RC-5 data structure in decoded format

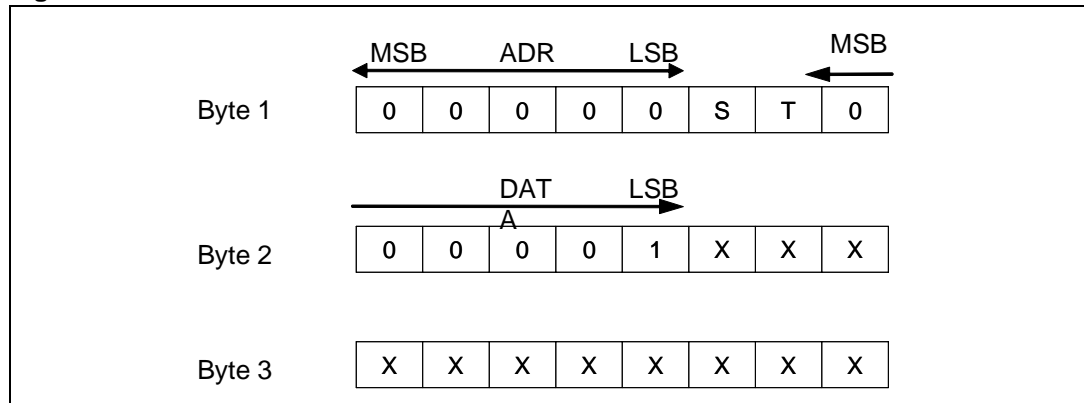

15.3.2 RC-5 data in RAW format

In the raw form, the data is sent in the same way as it is received for each RC protocol except that the header is not transmitted on SDA. So for the above example for Philips RC-5 protocol, the data on SDA pin in raw-format will be as follows:

Figure 29. RC-5 data structure in raw format

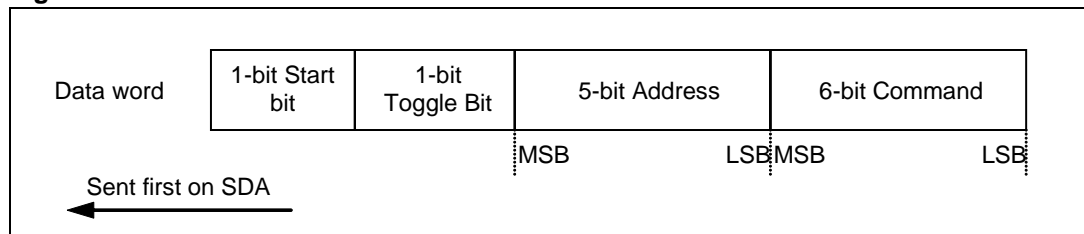

15.4 NEC remote control protocol

This remote control protocol uses pulse distance modulation. Each bit consists of a high level of fixed time T , followed by a low level that varies in width. A space that is T represents a logic "0" and a space that is $3T$ represents a logic 1. T is 0.56 ms.

The LSB is transmitted first as shown in *Figure 31*.

Figure 30. Pulse distance modulation

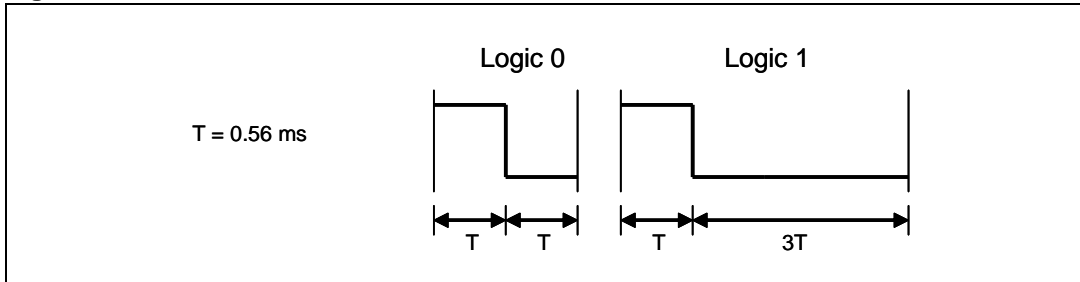
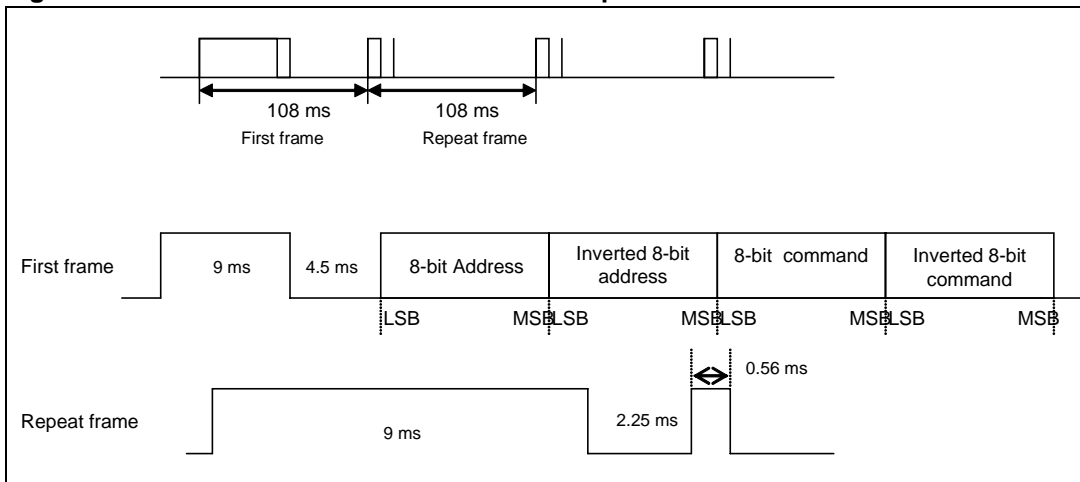

Figure 31. The transmitted waveform for NEC protocol



Note: The above waveform is on the transmitted side. The received data by the STFPC320 after the photo-diode is inverted from above.

15.4.1 NEC in decoded format

In the decoded form, the ADR bits followed by Start bit and Toggle Bit followed by Data bits are sent in this order for each remote control protocol. The number of bits depends on the corresponding RC protocol. The remaining empty bits are stuffed with 1's to complete a byte-aligned data frame.

Example for NEC protocol, if the 8-bit ADDR field is "00000010" and 8-bit command is "00011111", the in decoded format the data on SDA pin will be sent as follows with MSB transmitted first.

Figure 32. NEC data structure in decoded format

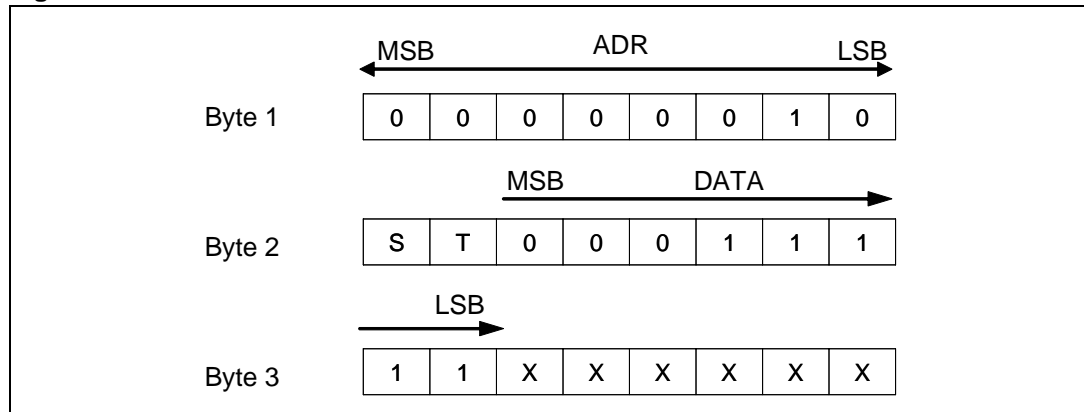

15.4.2 NEC in RAW format

In the raw form, the data is sent in the same way as it is received for each RC protocol except that the header is not transmitted on SDA. So for the above example for Philips RC-5 protocol, the data on SDA pin in raw-format will be as follows:

Figure 33. NEC data structure in raw format

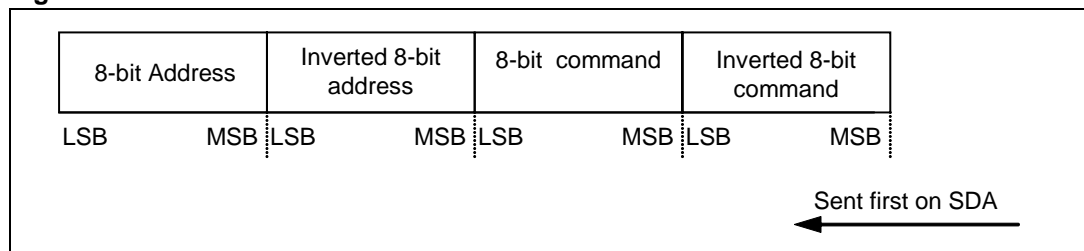

15.5 Sony remote control format

The modulated carrier is usually derived from 480kHz and is 1/12 of the frequency with 1/3 duty cycle.

When data are transmitted repeatedly, the frame cycle is 45 ms or 150 period.

A frame consists of a syn pulse, a seven-bit data code and a five-bit custom code.

Figure 34. Output code waveform timing definitions

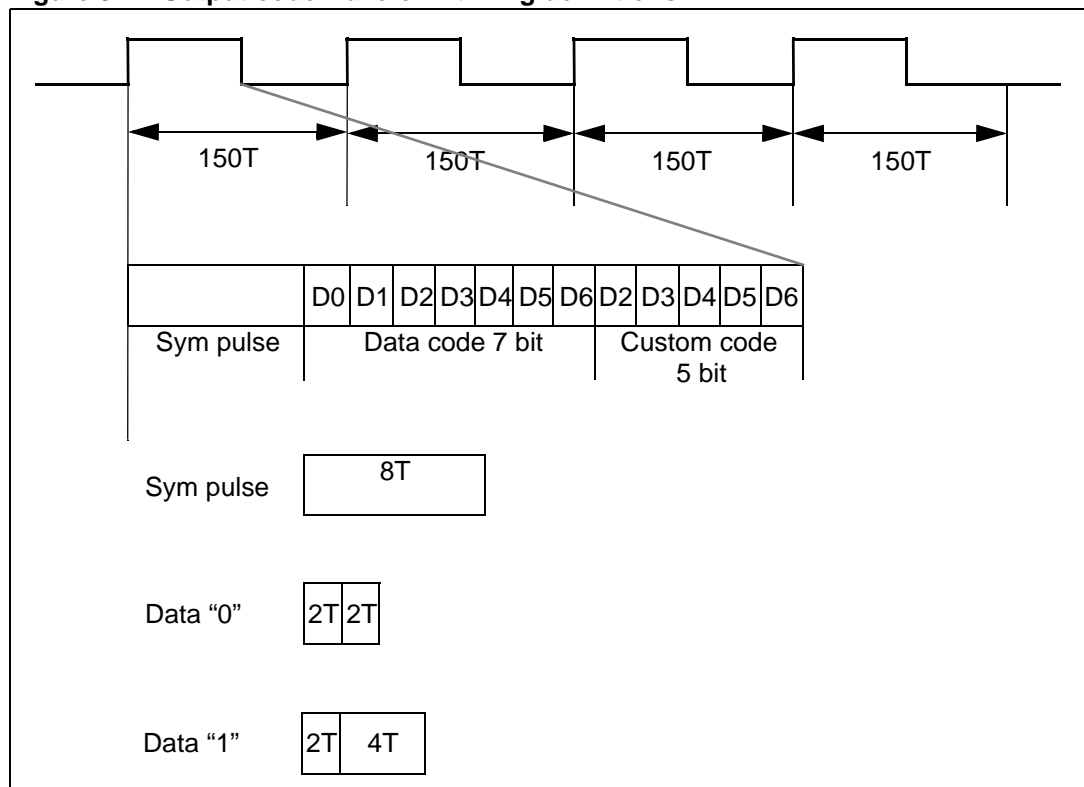

Table 13. Sony remote control format

| Data item | Time (sec) | Time (no. of period) |
|--------------------|------------|----------------------|
| Syn pulse | 2.4ms | 8T |
| Data off time | 0.61ms | 2T |
| Data on time (0) | 0.59ms | 2T |
| Data on time (1) | 1.19 | 4T |
| Data on time (0) | 1.2 | 4T |
| Data on time (1) | 1.8 | 6T |
| Frame output cycle | 45 | 150T |

Note: Where $T = 0.3ms$

Note that the above waveform is on the transmitted side. The received data by the STFPC320 after the photo-diode is inverted from above.

15.5.1 Sony in decoded format

In the decoded form, the ADR bits followed by Start bit and Toggle Bit followed by Data bits are sent in this order for each remote control protocol. The number of bits depends on the corresponding RC protocol. The remaining empty bits are stuffed with 1's to complete a byte-aligned data frame.

Example for Sony protocol, if the 5-bit custom code is “11000” and 7-bit data code is “1010100”, the in decoded format the data on SDA pin will be sent as follows with MSB transmitted first.

Figure 35. Sony data structure in decoded format

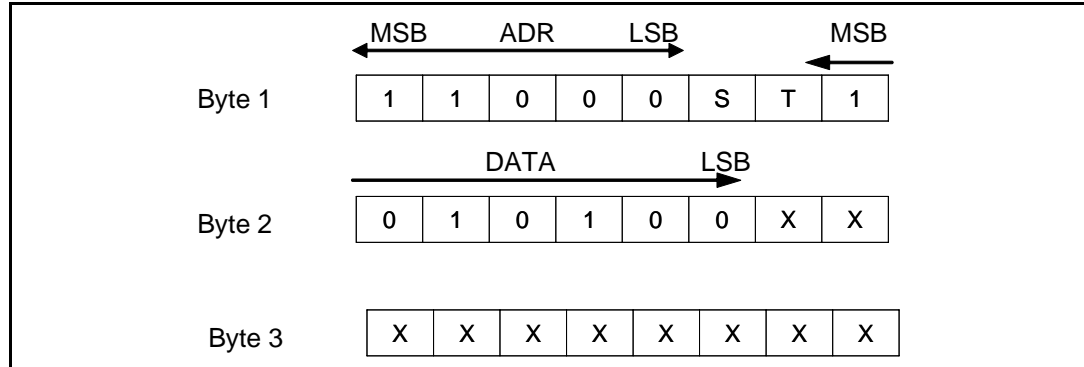

15.5.2 Sony in RAW format

In the raw form, the data is sent in the same way as it is received for each RC protocol except that the header is not transmitted on SDA. If a valid SYN pulse is detected, it is represented by a bit '1'. So a first bit with value '1' implies that the data following it is a valid raw format RC data. So for the above example for Sony protocol, the data on SDA pin in raw-format will be as in [Figure 36](#).

Figure 36. Sony data structure in raw format

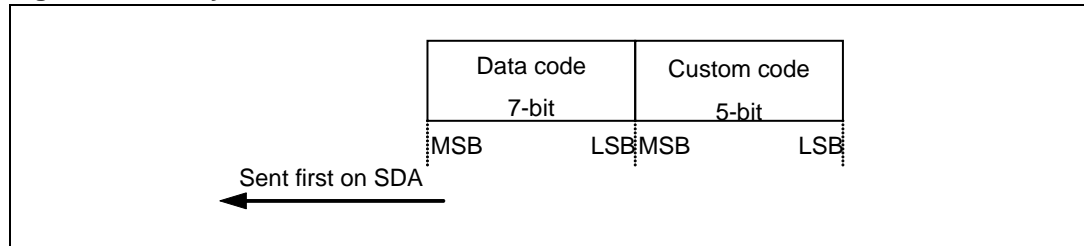

15.6 Matsushita remote control format

The modulated carrier is usually derived from 440 kHz and is 1/12 of the frequency with 1/2 duty cycle.

When data are transmitted repeatedly, the frame cycle is 104.7 ms or 240 period.

A frame consists of a syn pulse, a five-bit custom code, six-bit data code, a five-bit inverted custom code and a six-bit inverted data code.

The timing definitions of the output code waveform are shown in [Figure 37](#).

Figure 37. Matsushita remote control protocol

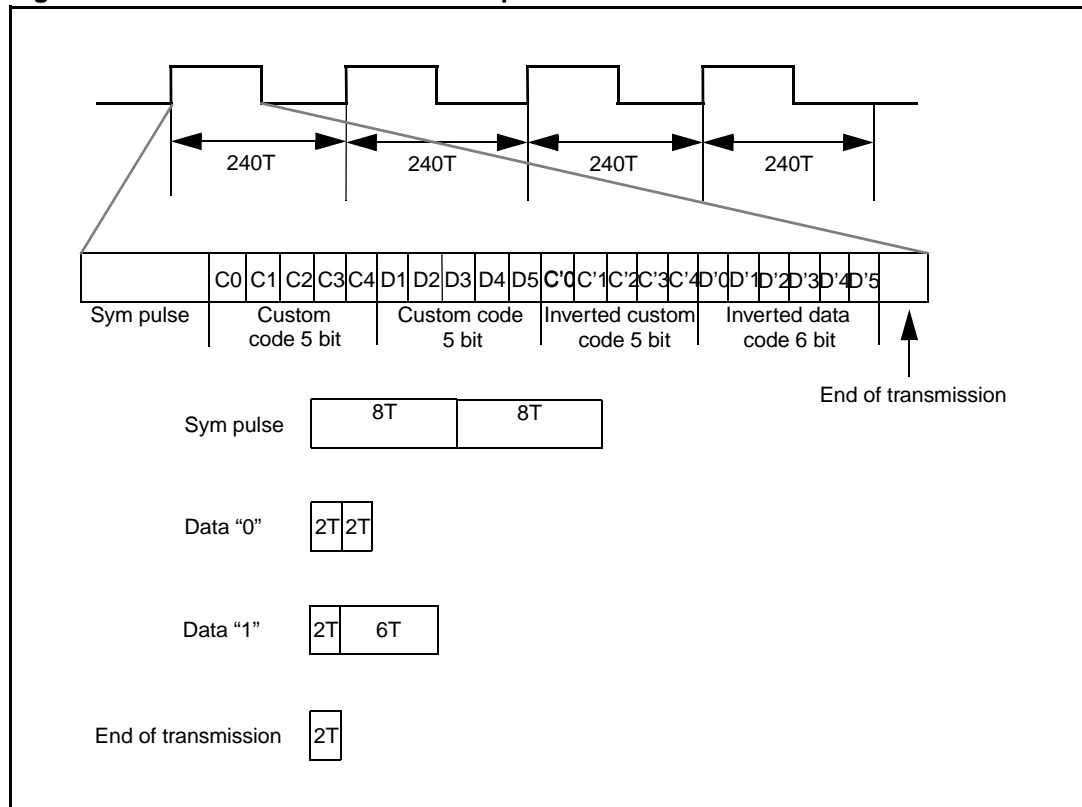

Table 14. Matsushita remote control format

| Data item | Time (sec) | Time (no. of period) |
|--------------------|------------|----------------------|
| Syn pulse on time | 3.49ms | 8T |
| Syn pulse off time | 3.49ms | 8T |
| Data on time (0) | 0.86ms | 2T |
| Data off time (0) | 0.88ms | 2T |
| Data on time (1) | 0.86ms | 2T |
| Data off time (1) | 2.63ms | 6T |
| Data period (0) | 1.74ms | 4T |
| Data period (1) | 3.49ms | 8T |
| Frame output cycle | 104.7ms | 240T |

Note: Where $T = 0.436\text{ ms}$

Note that the above waveform is on the transmitted side. The received data by the STFPC320 after the photo-diode is inverted from above.

15.6.1 Matsushita in decoded format

In the decoded form, the ADR bits followed by Start bit and Toggle Bit followed by Data bits are sent in this order for each remote control protocol. The number of bits depends on the corresponding RC protocol. The remaining empty bits are stuffed with 1's to complete a byte-aligned data frame.

For Matsushita protocol, if the 5-bit custom code is “11000” and 6-bit data code is “101010”, the in decoded format the data on SDA pin will be sent as follows with MSB transmitted first.

Figure 38. Matsushita data structure in decoded format

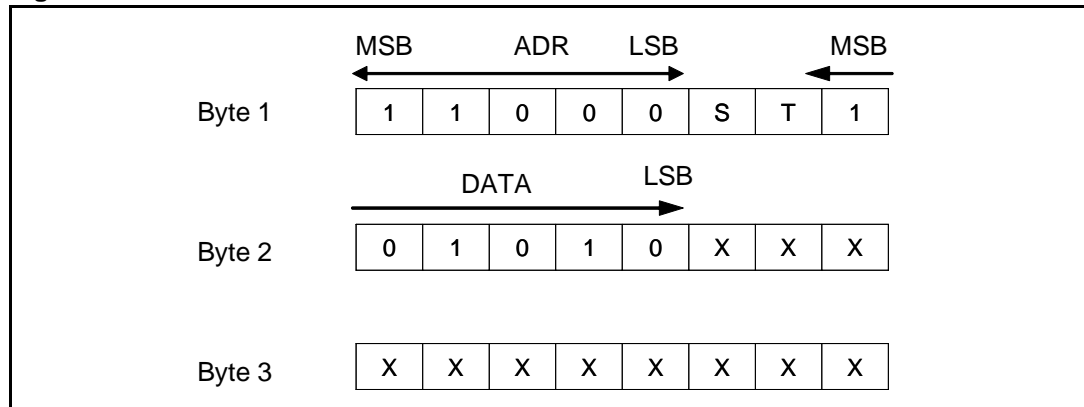

15.6.2 Matsushita in RAW format

In the raw form, the data is sent in the same way as it is received for each RC protocol except that the header is not transmitted on SDA. If a valid SYN pulse is detected, it is represented by a bit '1'. So a first bit with value '1' implies that the data following it is a valid raw format RC data. So for the above example for Matsushita protocol, the data on SDA pin in raw-format will be as in [Figure 39](#).

Figure 39. Matsushita data structure in raw format

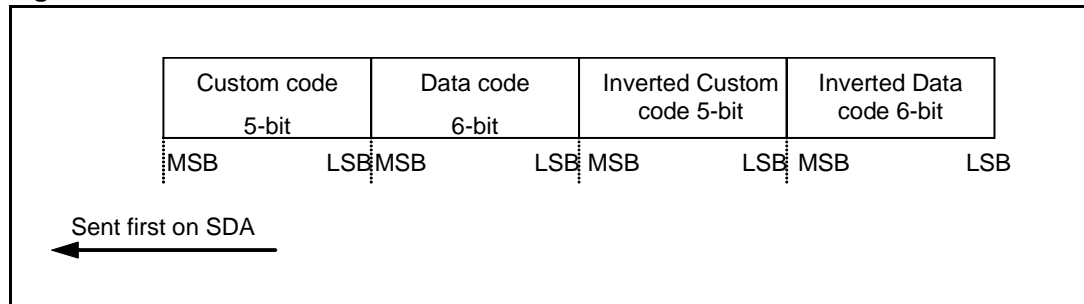

15.7 R2000 remote control format

Figure 40. Thomson R2000 remote control protocol

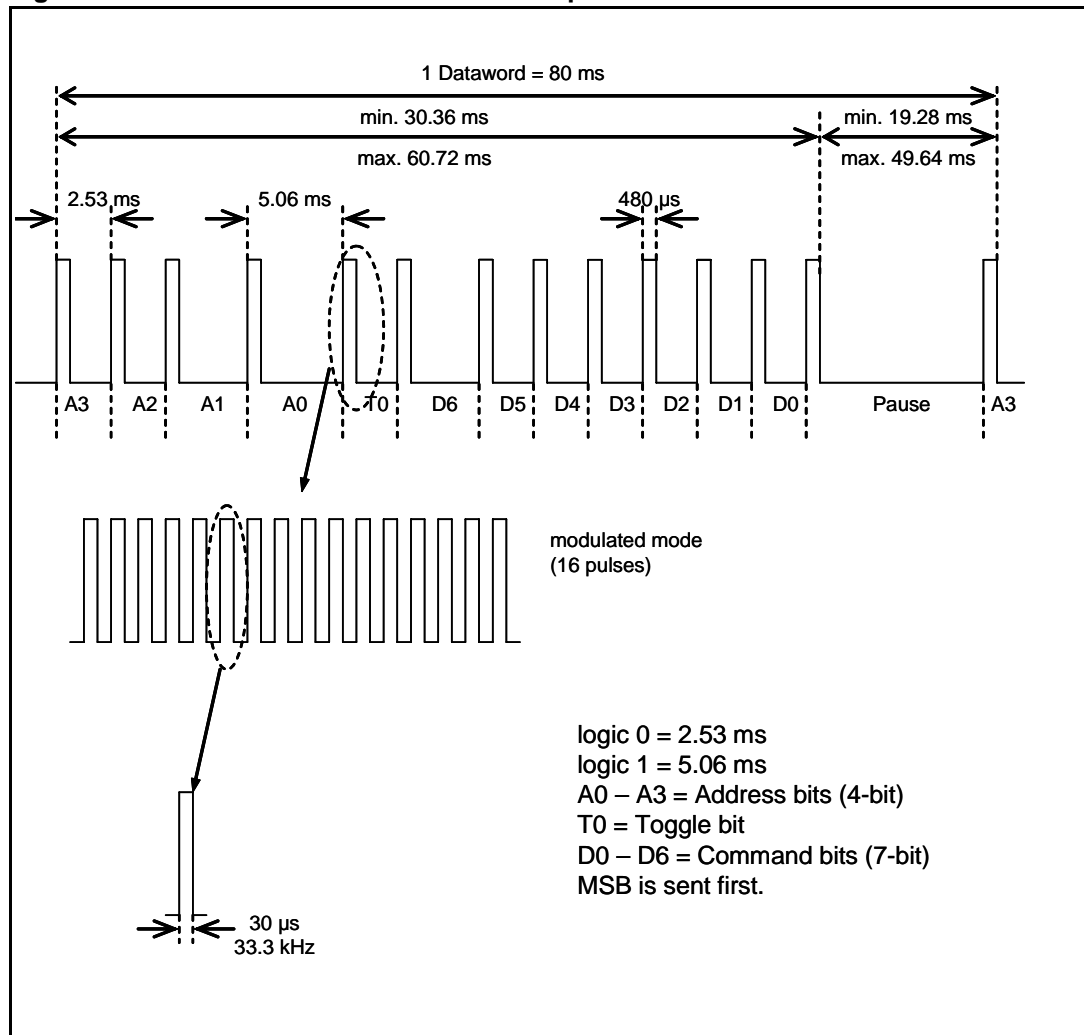

Note: The above waveform is on the transmitted side. The received data by the STFPC320 after the photo-diode is inverted from above.

15.7.1 R2000 in decoded format

In the decoded form, the ADR bits followed by Start bit and Toggle Bit followed by Data bits are sent in this order for each remote control protocol. The number of bits depends on the corresponding RC protocol. The remaining empty bits are stuffed with 1's to complete a byte-aligned data frame.

For the R2000 protocol, if the 4-bit ADR is “1101” and 7-bit command bits is “1010100”, the in decoded format the data on SDA pin will be sent as follows with MSB transmitted first.

Figure 41. R2000 data structure in decoded format

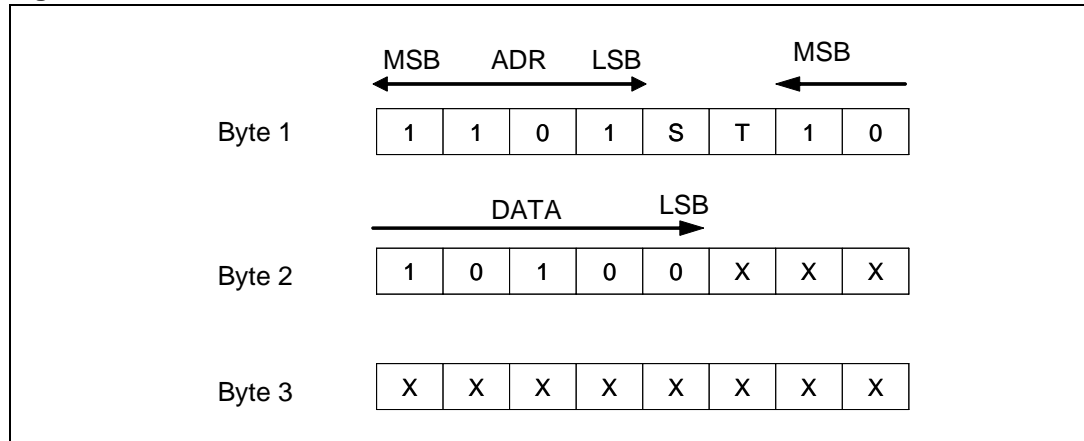

15.7.2 R2000 in RAW format

In the raw form, the data is sent in the same way as it is received for each RC protocol except that the header is not transmitted on SDA. So for the above example for R2000 protocol, the data on SDA pin in raw-format will be as in [Figure 42](#).

Figure 42. R2000 data structure in raw format

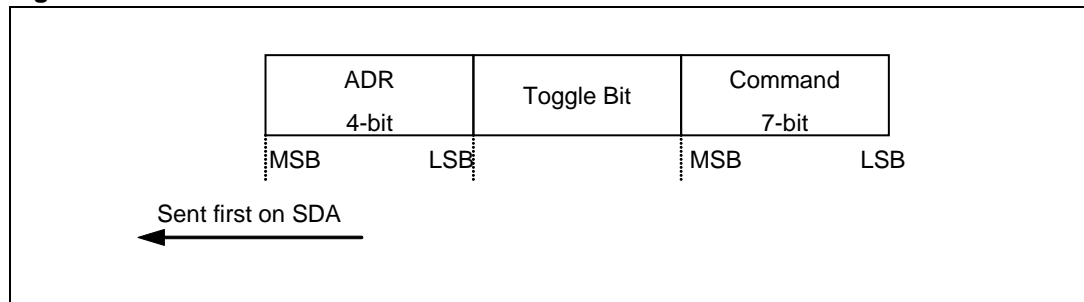

15.8 RCA remote control format

Figure 43. Thomson RCA remote control protocol

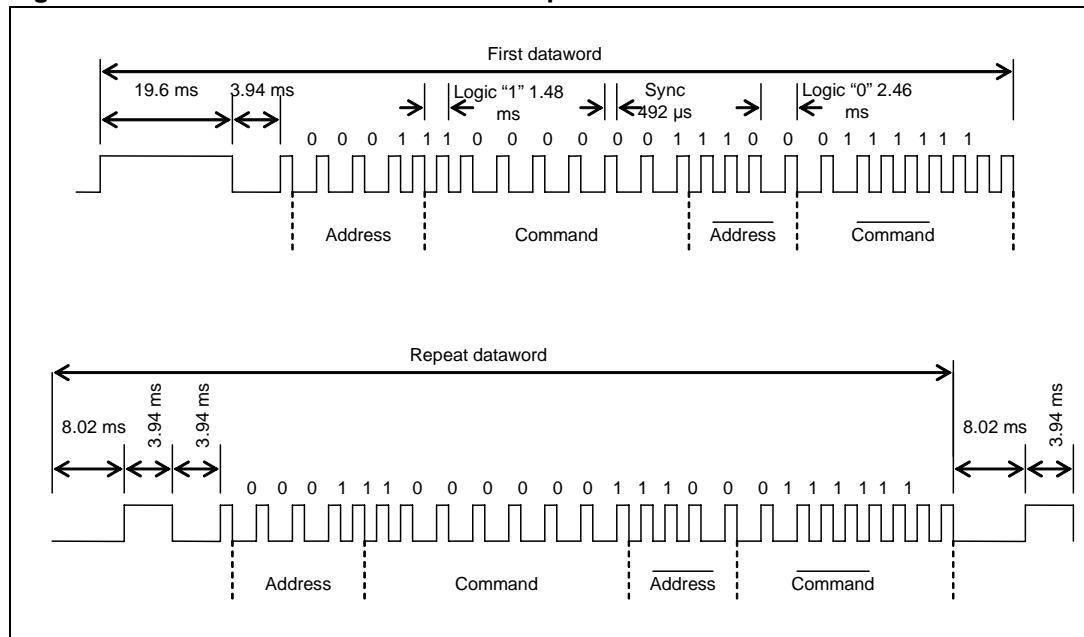

Note: The above waveform is on the transmitted side. The received data by the STFPC320 after the photo-diode is inverted from above.

15.8.1 RCA in decoded format

In the decoded form, the ADR bits followed by Start bit and Toggle Bit followed by Data bits are sent in this order for each remote control protocol. The number of bits depends on the corresponding RC protocol. The remaining empty bits are stuffed with 1's to complete a byte-aligned data frame.

For RCA protocol, if the 4-bit ADR is "1101" and 7-bit command bits is "1010100", the in decoded format the data on SDA pin will be sent as follows with MSB transmitted first.

Figure 44. RCA data structure in decoded format

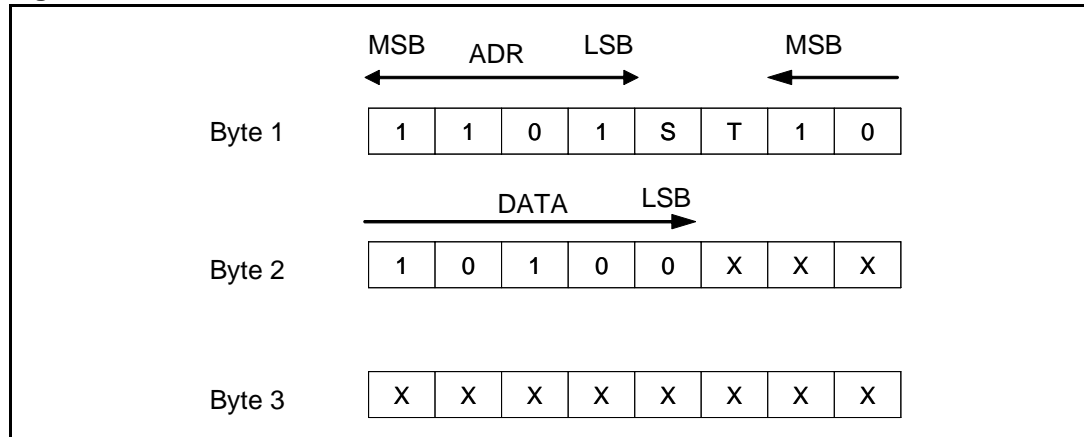

15.8.2 RCA in RAW format

In the raw form, the data is sent in the same way as it is received for each RC protocol except that the header is not transmitted on SDA. So for the above example for RCA protocol, the data on SDA pin in raw-format will be as follows:

Figure 45. RCA data structure in raw format

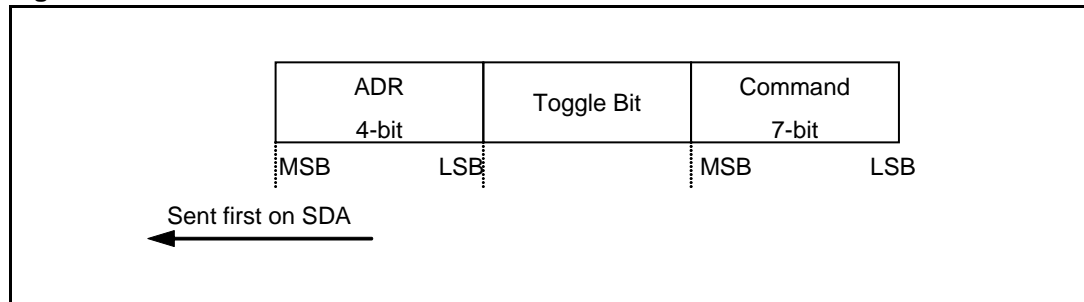

16 Serial communication format

Figure 46. Complete data transfer

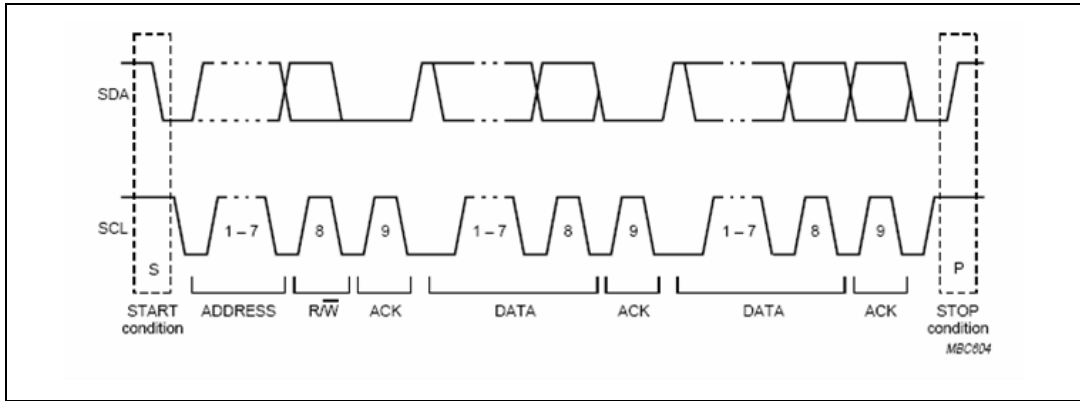

Figure 47. Valid data changes on the SDA bus

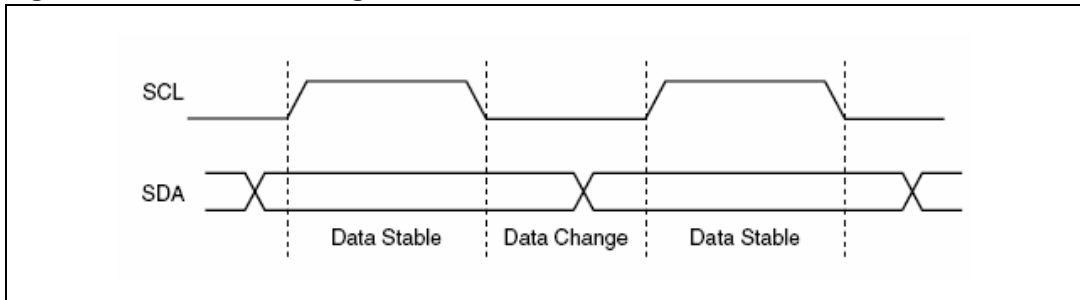

Figure 48. Valid start and stop conditions

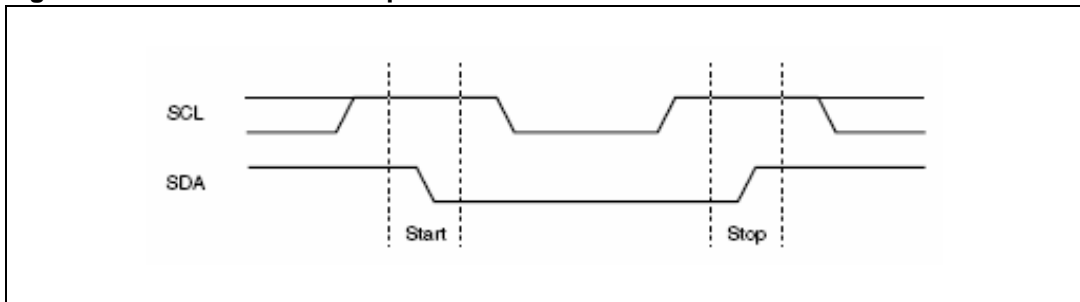

Figure 49. Acknowledge response from receiver

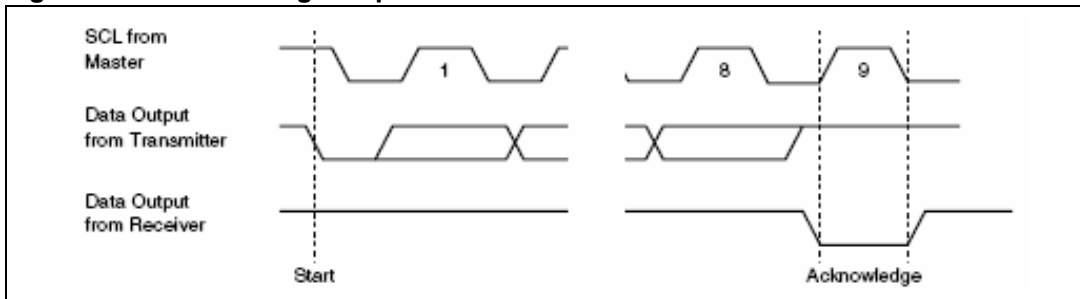

Figure 50. Bus timing requirements sequence

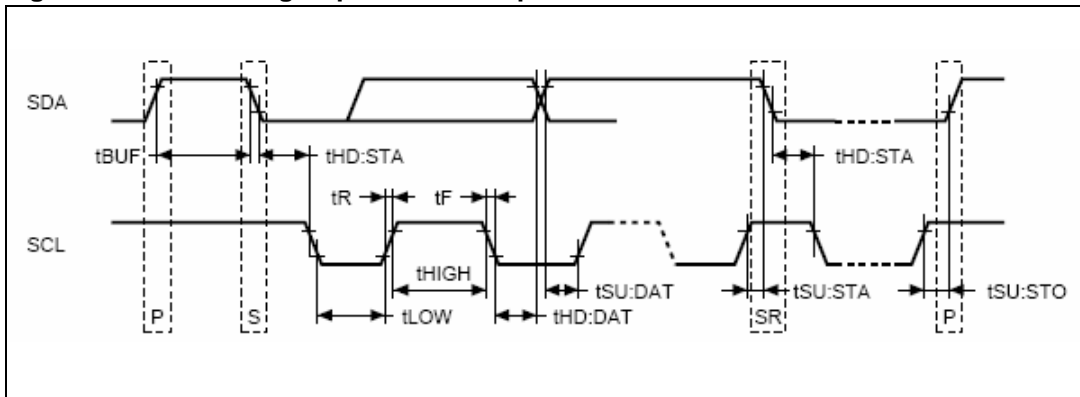

Figure 51. Slave address location

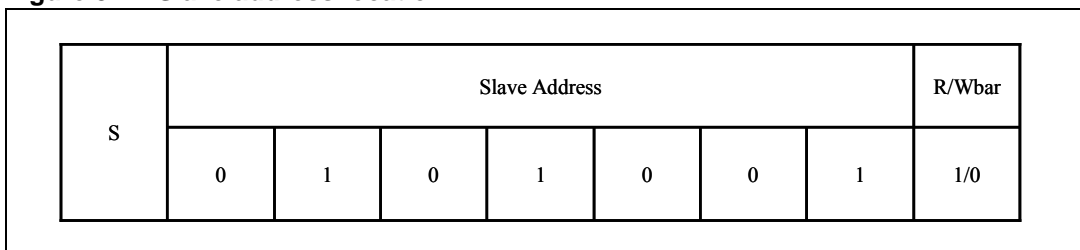
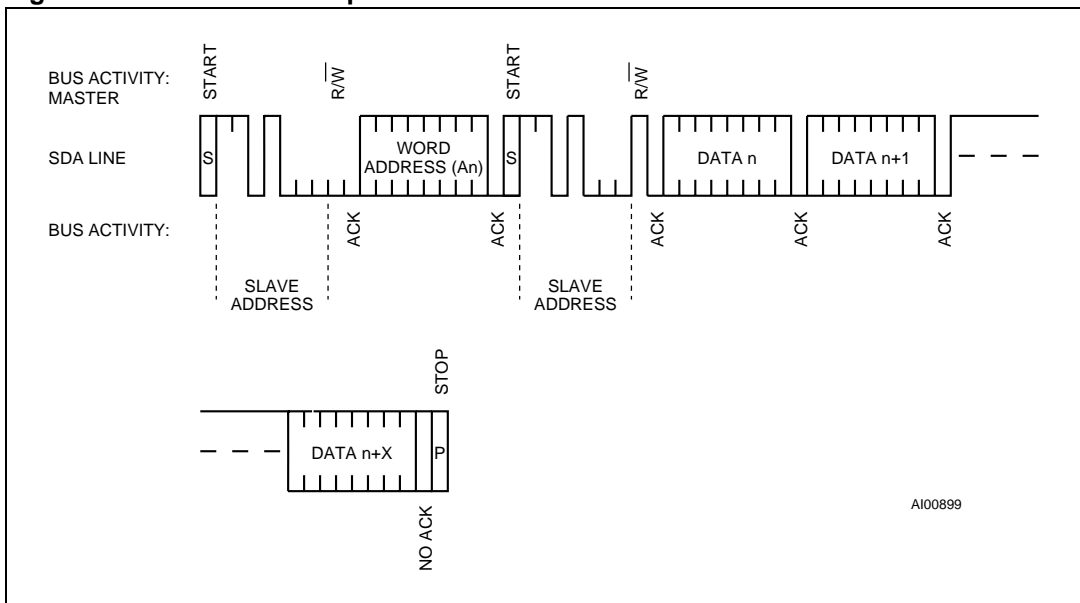

Figure 52. Read mode sequence



A100899

Figure 53. Alternative READ mode sequence

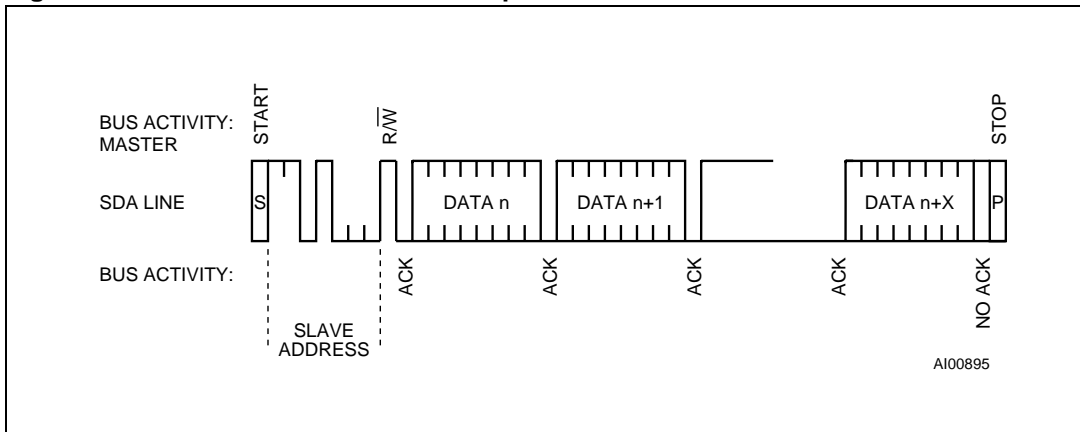
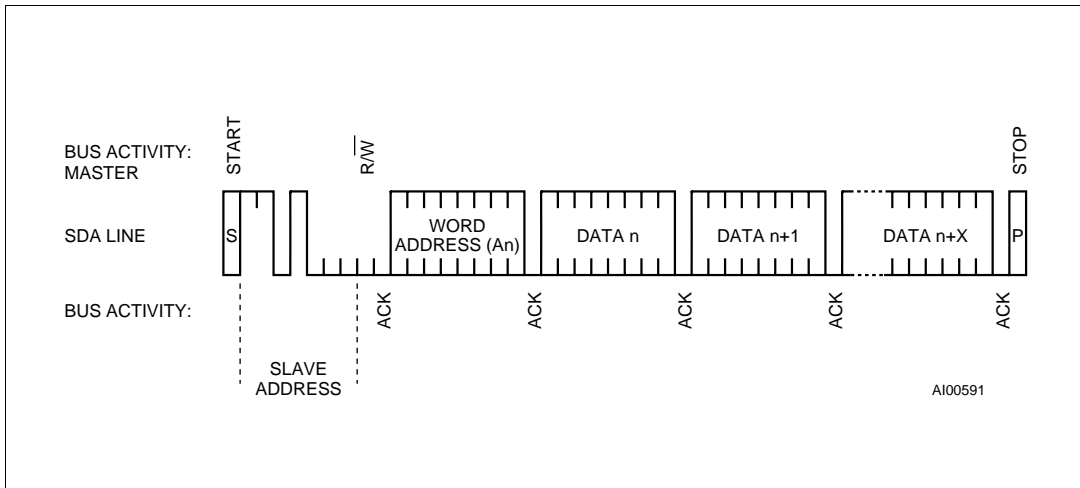

Figure 54. WRITE mode sequence



17 Electrical characteristics

17.1 Absolute maximum ratings

Table 15. Absolute maximum ratings ($T_A = 25^\circ\text{C}$, GND = 0 V)

| Symbol | Parameter | Value | Unit |
|-----------|-------------------------------|-----------------------------------|------------------|
| V_{DD} | Logic supply voltage | -0.5 to +4.0 | V |
| V_{SS} | Driver supply voltage | $V_{DD} + 0.5$ to $V_{DD} - 33.3$ | V |
| V_{I1} | Logic input voltage | -0.4 to $V_{DD} + 0.5$ | V |
| V_{O2} | VFP driver output voltage | $V_{SS} - 0.5$ to $V_{DD} + 0.5$ | V |
| I_{O1} | LED driver output current | +25 | mA |
| I_{O2} | VFP driver output current | -40 (grid) -15 (segment) | mA |
| P_D | Power dissipation | 1200 ⁽¹⁾ | mW |
| T_{opt} | Operating ambient temperature | -40 to +85 | $^\circ\text{C}$ |
| T_{stg} | Storage temperature | -65 to +150 | $^\circ\text{C}$ |

1. Derate at -9.6 mW/ $^\circ\text{C}$ at $T_A = 25^\circ\text{C}$ or higher

17.2 Recommended operating conditions

Table 16. Recommended operating conditions ($T_A = -20$ to $+70^\circ\text{C}$, GND = 0V)

| Symbol | Parameter | Min. | Typ. | Max. | Unit |
|----------|--------------------------|--------------|------|-----------------|------|
| V_{DD} | Logic supply voltage | | 3.3 | | V |
| V_{IH} | High-level input voltage | $0.7 V_{DD}$ | | V_{DD} | V |
| V_{IL} | Low-level input voltage | 0 | | $0.3 V_{DD}$ | V |
| V_{SS} | Driver supply voltage | 0 | | $V_{DD} - 33.3$ | V |

17.3 Power consumption estimation

Maximum power consumption $P_{MAX} = \text{VFD driver dissipation} + R_L \text{ dissipation} + \text{LED driver dissipation} + \text{dynamic power consumption}$.

Where segment current = 3 mA, grid current = 15 mA and LED current = 20 mA,

FIP driver dissipation = number of segments x 6 + number of grids/(number of grids + 1) x 30 (mW)

R_L dissipation = $(V_{DD} - V_{SS})^2/50 \times (\text{segment} + 1)$ (mW)

LED driver dissipation = number of LEDs x 20 (mW)

Dynamic power consumption = $V_{DD} \times 5$ (mW)

Example:

Where $V_{SS} = -30$ V, $V_{DD} = 3.3$ V and in 16-segment and 12-digit modes,

FIP driver dissipation = $16 \times 6 + 12/13 \times 30 = 124$

R_L dissipation = $33.32/50 \times 17 = 377$

LED driver dissipation = $2 \times 20 = 40$

Dynamic power consumption = $3.3 \times 5 = 16.5$

Total = 557.5 mW

17.4 Electrical specifications

Table 17. Electrical specifications

($T_A = -20$ to $+70$ °C, $V_{DD} = 3.3$ V, $GND = 0$ V, $V_{SS} = V_{DD} - 33.3$ V)

| Symbol | Parameter | Test conditions | Min | Typ | Max | Unit |
|-------------|-----------------------------|--|--------------|------|--------------|------|
| V_{OH1} | High-level output voltage | LED1 – LED4, $I_{OH1} = -1$ mA | $0.9 V_{DD}$ | | | V |
| V_{OL1} | Low-level output voltage | LED1 – LED4, $I_{OH2} = 20$ mA | | | 1 | V |
| V_{OL2} | Low-level output voltage | SDA, $I_{OL2} = 4$ mA | | | 0.6 | V |
| I_{OH21} | High-level output current | $V_O = V_{DD} - 2$ V, Seg ₁ to Seg ₁₂ | | | -3 | mA |
| I_{OH22} | High-level output current | $V_O = V_{DD} - 2$ V, Grid ₁ to Grid ₈ , Seg ₁₃ /Grid ₁₆ to Seg ₁₂ /Grid ₉ | | | -15 | mA |
| I_{OLEAK} | Driver leakage current | $V_O = V_{DD} - 33.3$ V, driver off | | | -10 | μA |
| R_L | Output pull-down resistor | Driver output | 50 | 100 | 150 | kΩ |
| I_I | Input current | $V_I = V_{DD}$ or GND | | | ±1 | μA |
| V_{IH} | High-level input voltage | | $0.7 V_{DD}$ | | | V |
| V_{IL} | Low-level input voltage | | | | $0.3 V_{DD}$ | V |
| V_H | Hysteresis voltage | | | 0.35 | | V |
| I_{DDdyn} | Dynamic current consumption | Under no load, display OFF | | | 2 | mA |
| R_{PU} | External pull-up resistor | SCL, SDA | | 4.7 | | kΩ |
| R_{PU} | External pull-up resistor | IRQ_N/SQW | | 10 | | kΩ |
| R_{PD} | External pull-down resistor | READY, KEY1, KEY2 | | 10 | | kΩ |

17.5 Crystal electrical characteristics

Table 18. Crystal electrical characteristics

| Symbol | Parameter ^{(1) (2)} | Min | Typ | Max | Units |
|--------|------------------------------|-----|--------|-------------------|------------|
| f_O | Resonant frequency | | 32.768 | | kHz |
| R_S | Series resistance | | 35 | 40 ⁽³⁾ | k Ω |
| C_L | Load capacitance | | 12.5 | | pF |

- Externally supplied. ST recommends the Citizen CFS-145 (1.5x5mm) and the KDS DT-38 (3x8mm) for thru-hole, or the KDS DMX-26S(3.2x8mm) for surface-mount, tuning fork-type quartz crystals. KDS can be contacted at kouhou@kdsj.co.jp or <http://www.kdsj.co.jp>. Citizen can be contacted at csd@citizen-americal.com or <http://www.citizen-crystal.com>
- Circuit board layout considerations for the 32.768KHz crystal of minimum trace lengths and isolation from RF generating signals should be taken into account.
- Guaranteed by design.

17.6 Oscillator characteristics

Table 19. Oscillator characteristics

| Symbol | Parameter | Conditions | Min | Typ | Max | Unit |
|-----------|---|------------------|-----|-----|-----|------|
| V_{STA} | Oscillator start voltage | ≤ 0 seconds | 1.5 | | | V |
| t_{STA} | Oscillator start time | $V_{CC} = 3.0$ V | | | 1 | s |
| C_{L1} | XIN | | | | 25 | pF |
| C_{L2} | XOUT | | | | 25 | pF |
| | IC-to-IC frequency variation ⁽¹⁾ | | -10 | | +10 | ppm |

- Reference value. $T_A = 25^\circ\text{C}$, $V_{CC} = 3.0\text{V}$, CFM-145 (CL = 6pF, 32.768 KHz) manufactured by Citizen

17.7 Timing characteristics

$V_{DD} = 3.3\text{ V}$, $T_A = -20\text{ to }70^\circ\text{C}$, unless otherwise noted. Typical values are at $T_A = 25^\circ\text{C}$

Figure 55. Key scanning and display timing

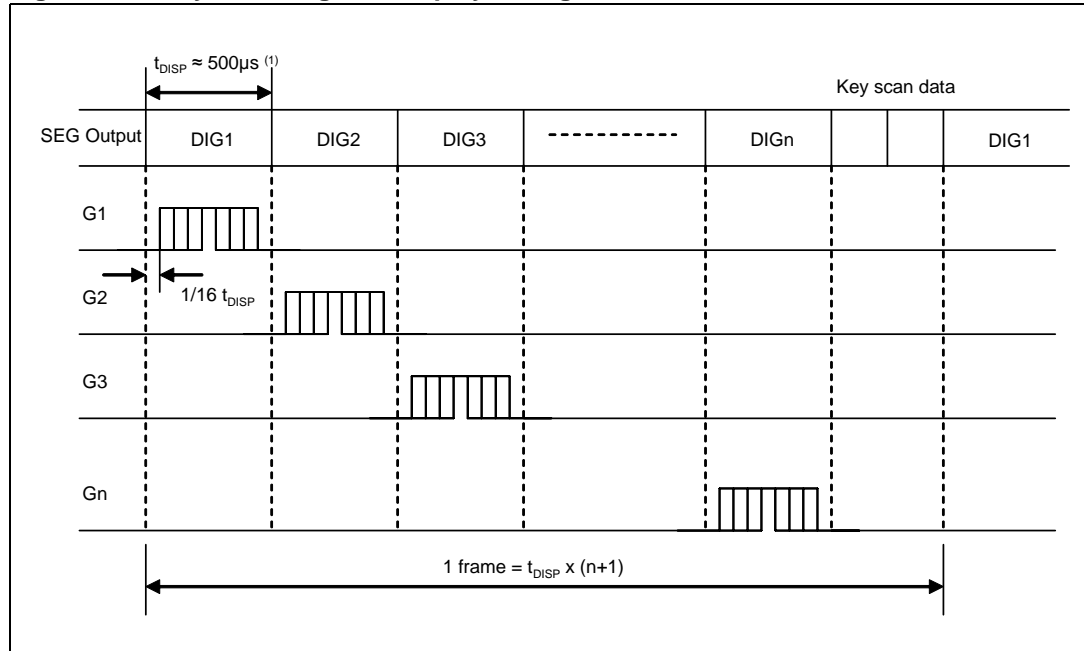

Note: Pulse width of segment signal is decided by oscillator frequency. The value can be modified by trimming R_{OSC} . One cycle of key scanning consists of one frame and data of 12 x 2 matrices are stored in RAM. The keyscan is only at the end of the frame when the display is ON. When the display is OFF, the key scan takes place continuously. The grid is turned off during the key scan.

17.8 Switching characteristics

Table 20. Switching characteristics
($T_A = -20$ to $+70$ °C, $V_{DD} = 3.3V$, $V_{SS} = -30V$)

| Symbol | Parameter | Min | Typ | Max | Units |
|--------------|---|-----|-----|-----|---------|
| f_{SCL} | SCL clock frequency | 0 | | 400 | kHz |
| t_{LOW} | Clock low period | 1.3 | | | μs |
| t_{HIGH} | Clock high period | 600 | | | ns |
| t_R | SDA and SCL rise time | | | 300 | ns |
| t_F | SDA and SCL fall time | | | 300 | ns |
| $t_{HD:STA}$ | START condition hold time (After this period the first clock pulse is generated) | 600 | | | ns |
| $t_{SU:STA}$ | START condition setup time (only relevant for a repeated start condition) | 600 | | | ns |
| $t_{SU:DAT}$ | Data setup time ⁽¹⁾ | 100 | | | ns |
| $t_{HD:DAT}$ | Data hold time | 0 | | | μs |
| $t_{SU:STO}$ | STOP condition setup time | 600 | | | ns |
| t_{BUF} | Time the bus must be free before a new transmission can start | 1.3 | | | μs |
| t_{rec} | Watchdog output pulse width | 96 | | 98 | ms |
| t_{UNMUTE} | Time delay of turning off MUTE after READY is set high | 10 | | 80 | ns |
| t_{MUTE} | Time delay of turning on MUTE before STBY is set high | 10 | | 80 | ns |

1. Transmitter must internally provide a hold time to bridge the undefined region (300ns max) of the falling edge of the SCL.

Table 21. Switching characteristics ($T_A = -20$ to $+70$ °C, $V_{DD} = 3.3V$, $V_{SS} = -30V$)

| Symbol | Parameter | Test conditiong | Min. | Typ. | Max. | Unit |
|------------|------------------------|--|------|------|------|---------|
| t_{OSC} | Oscillation frequency | $R = 33\text{ k}\Omega \pm 1\%$ | 430 | 500 | 565 | kHz |
| t_{PLZ} | Propagation delay time | CLK -> SDA | | | 300 | ns |
| t_{PZL} | | $C_L = 15\text{ pF}$, $R_L = 10\text{ k}\Omega$ | | | 100 | ns |
| t_{TZH1} | Rise time | $C_L = 300\text{ pF}$ Seg ₁ to Seg ₁₂ | | | 2 | μs |
| t_{TZH2} | | Grid ₁ to Grid ₈ , Seg ₁₃ /Grid ₁₆ to Seg ₂₀ /Grid ₉ | | | 0.5 | μs |
| t_{THZ} | Fall time | $C_L = 300\text{ pF}$, Seg _n , Grid _n | | | 120 | μs |
| C_I | Input capacitance | | | | 15 | pF |

18 STFPC320 typical application circuit

Figure 56. Typical application circuit

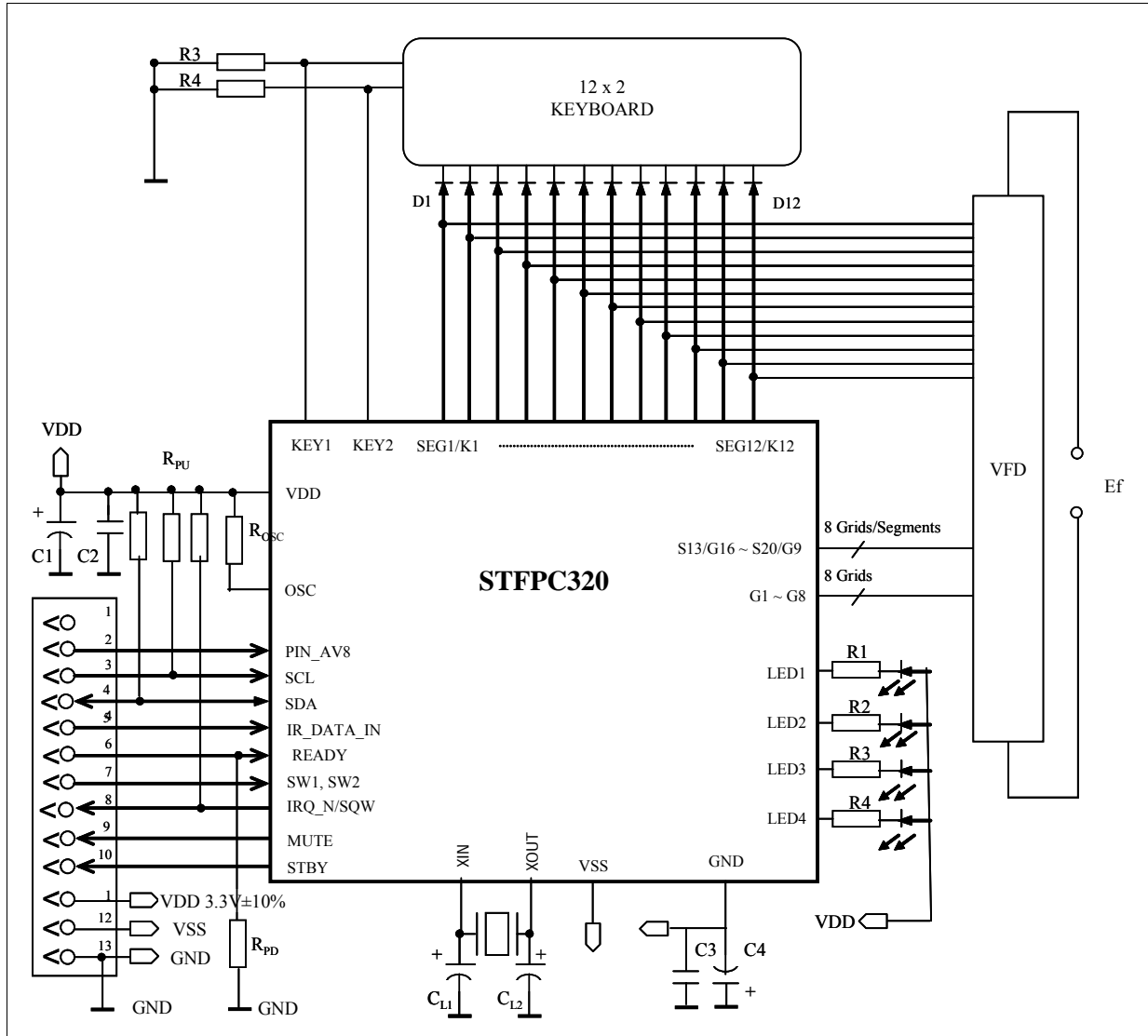

$R_{OSC} = 33k\Omega (\pm 1\%)$ for oscillator resistor;

$R1 \sim R4 = 0.75 \sim 1.2k\Omega$;

$R3, R4 = 10k\Omega$ for external keyboard pull-down resistor;

$R_{PU} = 4.7k\Omega$ for external pull-up resistor on SDA, SCL;

$R_{PU} = 10k\Omega$ for external pull-up resistor on IRQ_N/SQW;

$R_{PD} = 10k\Omega$ for external pull-down resistor on READY;

$C_{L1}, C_{L2} = 25pF$;

$C1 = 33\mu F-25V$ electrolytic;

$C2 = 0.01 \sim 0.1\mu F-25V$ ceramic;

$C3 = 0.01 \sim 0.1\mu F-63V$ ceramic;

$C4 = 33\mu F-63V$ electrolytic;

$D1 \sim D12 = 1N4148$;

Ef = filament voltage according to the VFD specs;

VDD = $3.3V \pm 10\%$;

VSS = down to VDD - 33.3V.

19 Package mechanical data

In order to meet environmental requirements, ST offers these devices in ECOPACK® packages. These packages have a Lead-free second level interconnect . The category of second level interconnect is marked on the package and on the inner box label, in compliance with JEDEC Standard JESD97. The maximum ratings related to soldering conditions are also marked on the inner box label. ECOPACK is an ST trademark. ECOPACK specifications are available at: www.st.com.

Figure 57. PQFP52L package outline

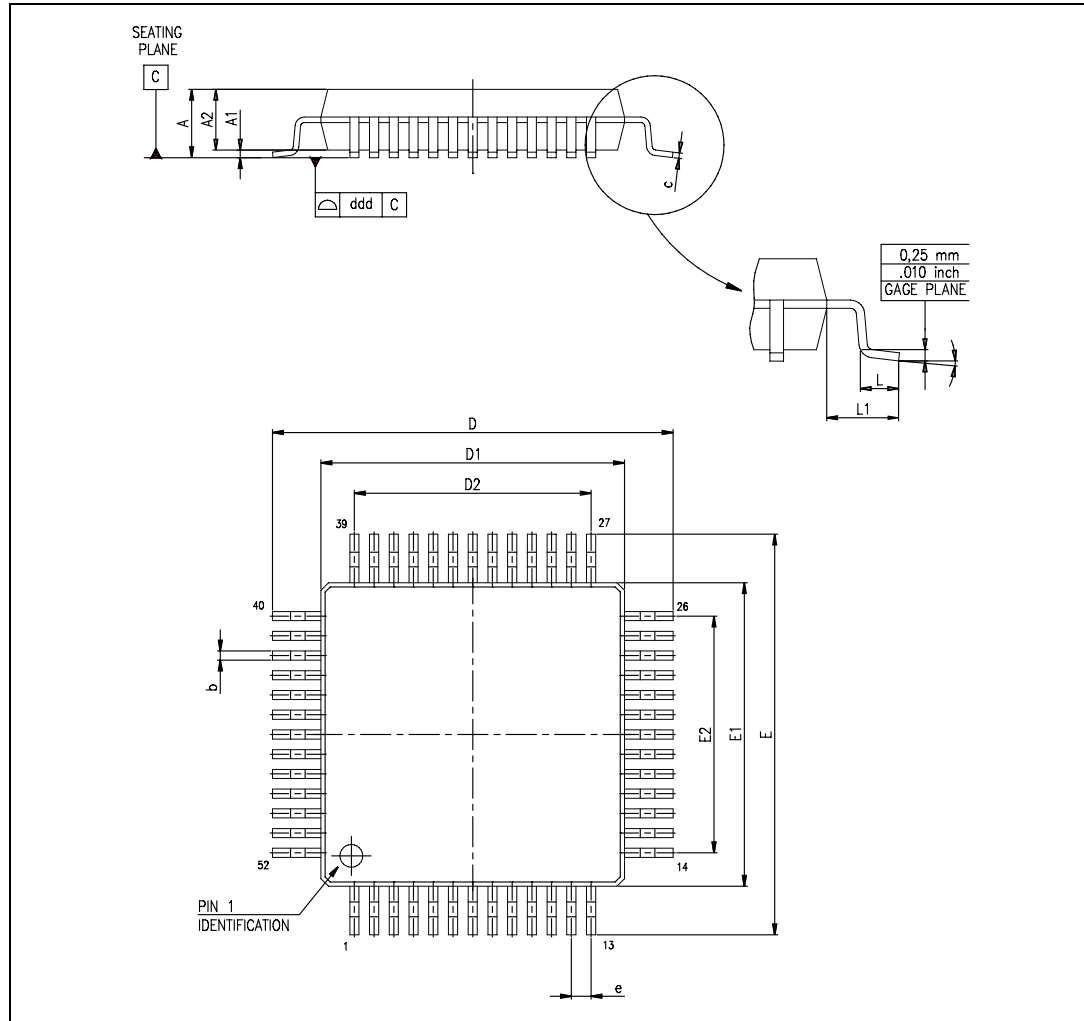
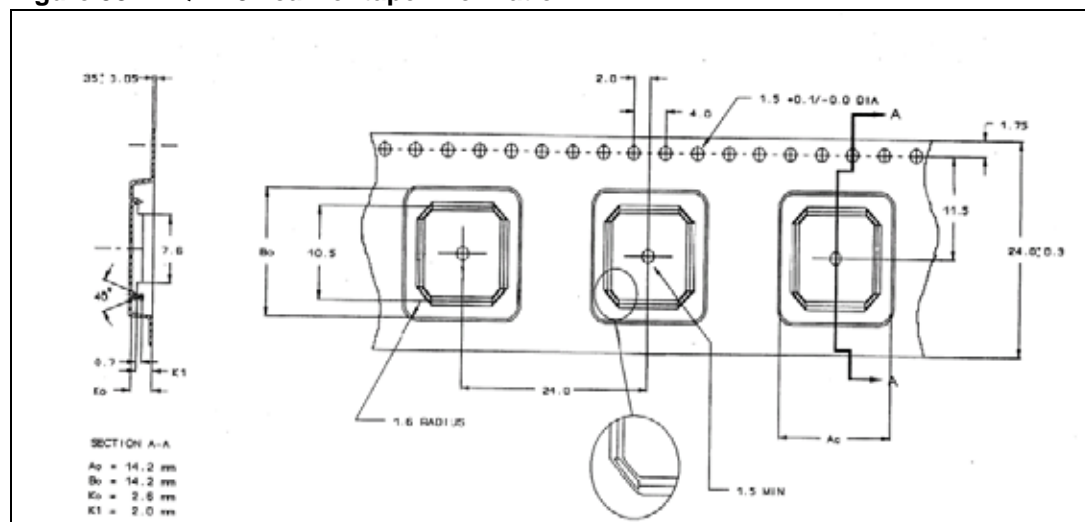

Table 22. PQFP52 (10 x 10 x 2 mm) mechanical data

| Symbol | Millimeters | | |
|--------|-------------|--------|--------|
| | Min | Typ | Max |
| A | | | 2.450 |
| A1 | | | 0.250 |
| A2 | 1.800 | 2.000 | 2.200 |
| b | 0.220 | | 0.400 |
| c | 0.110 | | 0.230 |
| D | 12.950 | 13.200 | 13.450 |
| D1 | 9.800 | 10.000 | 10.200 |
| D2 | | 7.800 | |
| E | 12.950 | 13.200 | 13.450 |
| E1 | 9.800 | 10.000 | 10.200 |
| E2 | | 7.800 | |
| e | | 0.650 | |
| L | 0.730 | 0.880 | 1.030 |
| L1 | | 1.600 | |
| k | 0° | | 7° |
| ddd | | | 0.100 |

Figure 58. PQFP-52 carrier tape information



20 Revision history

Table 23. Document revision history

| Date | Revision | Changes |
|-------------|----------|--|
| 08-Jan-2006 | 1 | Initial release. |
| 07-Jul-2008 | 2 | Document reformatted to conform to new ST template. Modified: package mechanical data. Added: tape specifications. |

Please Read Carefully:

Information in this document is provided solely in connection with ST products. STMicroelectronics NV and its subsidiaries ("ST") reserve the right to make changes, corrections, modifications or improvements, to this document, and the products and services described herein at any time, without notice.

All ST products are sold pursuant to ST's terms and conditions of sale.

Purchasers are solely responsible for the choice, selection and use of the ST products and services described herein, and ST assumes no liability whatsoever relating to the choice, selection or use of the ST products and services described herein.

No license, express or implied, by estoppel or otherwise, to any intellectual property rights is granted under this document. If any part of this document refers to any third party products or services it shall not be deemed a license grant by ST for the use of such third party products or services, or any intellectual property contained therein or considered as a warranty covering the use in any manner whatsoever of such third party products or services or any intellectual property contained therein.

UNLESS OTHERWISE SET FORTH IN ST'S TERMS AND CONDITIONS OF SALE ST DISCLAIMS ANY EXPRESS OR IMPLIED WARRANTY WITH RESPECT TO THE USE AND/OR SALE OF ST PRODUCTS INCLUDING WITHOUT LIMITATION IMPLIED WARRANTIES OF MERCHANTABILITY, FITNESS FOR A PARTICULAR PURPOSE (AND THEIR EQUIVALENTS UNDER THE LAWS OF ANY JURISDICTION), OR INFRINGEMENT OF ANY PATENT, COPYRIGHT OR OTHER INTELLECTUAL PROPERTY RIGHT.

UNLESS EXPRESSLY APPROVED IN WRITING BY AN AUTHORIZED ST REPRESENTATIVE, ST PRODUCTS ARE NOT RECOMMENDED, AUTHORIZED OR WARRANTED FOR USE IN MILITARY, AIR CRAFT, SPACE, LIFE SAVING, OR LIFE SUSTAINING APPLICATIONS, NOR IN PRODUCTS OR SYSTEMS WHERE FAILURE OR MALFUNCTION MAY RESULT IN PERSONAL INJURY, DEATH, OR SEVERE PROPERTY OR ENVIRONMENTAL DAMAGE. ST PRODUCTS WHICH ARE NOT SPECIFIED AS "AUTOMOTIVE GRADE" MAY ONLY BE USED IN AUTOMOTIVE APPLICATIONS AT USER'S OWN RISK.

Resale of ST products with provisions different from the statements and/or technical features set forth in this document shall immediately void any warranty granted by ST for the ST product or service described herein and shall not create or extend in any manner whatsoever, any liability of ST.

ST and the ST logo are trademarks or registered trademarks of ST in various countries.

Information in this document supersedes and replaces all information previously supplied.

The ST logo is a registered trademark of STMicroelectronics. All other names are the property of their respective owners.

© 2008 STMicroelectronics - All rights reserved

STMicroelectronics group of companies

Australia - Belgium - Brazil - Canada - China - Czech Republic - Finland - France - Germany - Hong Kong - India - Israel - Italy - Japan - Malaysia - Malta - Morocco - Singapore - Spain - Sweden - Switzerland - United Kingdom - United States of America

www.st.com